



Installing and Connecting the MDF and Telephones

03-300686
Issue 3
Release 5.0
January 2008

© 2008 Avaya Inc.
All Rights Reserved.

Notice

While reasonable efforts were made to ensure that the information in this document was complete and accurate at the time of printing, Avaya Inc. can assume no liability for any errors. Changes and corrections to the information in this document may be incorporated in future releases.

For full support information, please see the complete document, *Avaya Support Notices for Hardware Documentation*, document number 03-600759, and the complete document, *Avaya Support Notices for Software Documentation*, document number 03-600758.

To locate these document on our Web site, simply go to <http://www.avaya.com/support> and search for the document number in the search box.

Documentation disclaimer

Avaya Inc. is not responsible for any modifications, additions, or deletions to the original published version of this documentation unless such modifications, additions, or deletions were performed by Avaya. Customer and/or End User agree to indemnify and hold harmless Avaya, Avaya's agents, servants and employees against all claims, lawsuits, demands and judgments arising out of, or in connection with, subsequent modifications, additions or deletions to this documentation to the extent made by the Customer or End User.

Link disclaimer

Avaya Inc. is not responsible for the contents or reliability of any linked Web sites referenced elsewhere within this documentation, and Avaya does not necessarily endorse the products, services, or information described or offered within them. We cannot guarantee that these links will work all of the time and we have no control over the availability of the linked pages.

Warranty

Avaya Inc. provides a limited warranty on this product. Refer to your sales agreement to establish the terms of the limited warranty. In addition, Avaya's standard warranty language, as well as information regarding support for this product, while under warranty, is available through the following Web site: <http://www.avaya.com/support>.

Copyright

Except where expressly stated otherwise, the Product is protected by copyright and other laws respecting proprietary rights. Unauthorized reproduction, transfer, and or use can be a criminal, as well as a civil, offense under the applicable law.

Avaya support

Avaya provides a telephone number for you to use to report problems or to ask questions about your product. The support telephone number is 1-800-242-2121 in the United States. For additional support telephone numbers, see the Avaya Web site: <http://www.avaya.com/support>.

Contents

Chapter 1: Introduction	9
Audience	9
How to use this documentation	9
Downloading this book and updates from the Web	10
Sending us comments.	11
Related resources	11
Chapter 2: Installing the main distribution frame	13
Physical requirements and layout	13
Installation space requirements	13
Installation layout	14
Main distribution frame cross-connect fields	16
Main distribution frame hardware installation	17
Main distribution frame placement	19
Main distribution frame labels	20
Mounting 110A- or 110P-type terminal blocks on the wall	21
Mounting 110P-type terminal blocks on a frame	24
Installing Cable Slack Managers	25
Chapter 3: Installing the patch panel.	29
Installing patch panels	29
Cross-connecting the media gateway to the patch panels	29
Chapter 4: Media gateway connections to the MDF.	33
Equipment room cabling labels	33
Cable routing guidelines	36
Trunk cables among network interface, sneak fuse panel, and media gateway	38
Installing cables between media gateway and MDF	38
Installing connector cables between auxiliary cabinet and MDF	39
Chapter 5: MDF connections to stations and the public switched telephone network.	41
Station (telephone) wiring design	41
Information outlets	41
Station cables	42
Closets	43
Satellite locations	43

Contents

Site locations	44
Station circuit distribution from equipment room	44
4-pair station circuits	45
3-pair to 4-pair station circuit distribution	45
Connected cable station adapters	50
Completing a provisioning plan	52
Installing sneak current and off premise protection	54
Installing sneak fuse panels	57
Installing the coupled bonding conductor	58
Installing coupled bonding conductor wires	58
Installing and administering the patch cord/jumper	62
Labeling expansion control carrier cable (MCC1 Media Gateway only)	64
Connecting expansion control carrier outputs cable (MCC1 Media Gateway only)	65
Connecting trunk pairs using concentrator cables	65
Connecting trunk pairs to media gateway using jumper wires to establish 3-pair modularity	67
Chapter 6: Installing and wiring telephones and trunks	69
Wiring telephones and trunks	69
Connecting telephones	70
Connectable telephones and consoles	70
Connecting a typical telephone	73
Connecting adjunct power	74
Connecting an analog station or 2-wire digital station	75
Analog tie trunk example	76
Digital tie trunk example	77
DS1 tie trunk example	78
Collocated DS1 interface trunks	78
DS1 interface trunks using T1 channel service unit.	79
Auxiliary connector outputs (MCC1 and SCC1 Media Gateways only)	81
Three-pair and four-pair modularity	84
Adjunct power connection locations	85
Attendant console example	86
Attendant console cabling distances, local and phantom power	86
Auxiliary power	86
Hard-wire bridging	87

Dual wiring of 2-wire and 4-wire endpoints	87
Installing the attendant console	87
Installing the 26B1 Selector Console	88
Connecting external alarm indicators and auxiliary power	88
Installing off-premises station wiring	90
Off-premises or out-of-building stations	91
Off-premises connections	91
Off-premises protection requirements	93
Telephone restrictions for exposed environments	94
Digital Out-of-Building Telephone Protection	94
Installing the ITW Linx Enhanced Protector	95
Installing the 4C3S-75 Enhanced Protector	95
Installing the data link protector	95
Emergency transfer units and associated telephones	96
808A Emergency Transfer Panel and telephone installation examples	97
Installing the 808A Emergency Transfer Panel	99
Installing telephones used only for emergency transfer (trunk/auxiliary field)	104
Installing telephones used for emergency transfer and as normal extension (trunk/auxiliary field)	105
Installing external ringing	106
Installing the queue warning indicator	107
Chapter 7: Installing and wiring telephone power supplies	109
1145B2 power supply	109
Important warning for 1145B2 power supply	110
Mounting the 1145B2/1146B2 power supply	111
Installing the wall-mounting plates	114
Mounting the 1146B2 Power Distribution Unit	114
Installing the battery mounting/wiring	115
Installing the expanded power distribution unit	115
Powering up and testing the power supply	116
Wiring the 1146B2 Power Distribution Unit	117
Resetting LEDs on power distribution unit	118
1152A1 Mid-Span Power Distribution Unit	119
Important safety instructions	119
Using the 1152A1 Power Distribution Unit	120
Connecting the 1152A1 Power Distribution Unit	120
Connecting the cables	121

Contents

Connecting cables to telephones and other end devices	122
1152B Mid-Span Power Distribution Units	123
Important 1152B PDU Safety Instructions	124
Using the 1152B PDUs	125
Connecting the 1152B PDU cables	125
Connecting cables to telephones and other end devices.	126
C360 converged stackable switches	128
C360 switch important safety instructions.	128
Using the C360 switch.	129
Connecting the C360 stackable switches	130
Connecting the cables.	131
1151B1 and 1151B2 Power Supplies	131
Important safety instructions for 1151B1 and 1151B2 Power Supplies	132
Using 1151B1 and 1151B2 Power Supplies	132
Connecting the 1151B1 or 1151B2 Power Supplies	133
Chapter 8: Testing the complete configuration	135
Testing port network equipment	136
Checking port network status for each media gateway	136
Checking circuit pack configuration	137
Testing the TN2312BP Internet Protocol Server Interface circuit pack	138
Testing Expansion Interface circuit packs, if used	139
Testing time division multiplexing bus for each port network	140
Testing expansion interface exchange, if used, for each port network	141
Testing telephones and other equipment	142
Making test calls	143
Testing 302C attendant console	143
Testing selector console	144
Testing external ringing	144
Testing queue warning indicator	144
Testing integrated announcement	144
Record an announcement	145
Playback announcement	145
Delete announcement	145
Testing music-on-hold	145
Testing emergency transfer (Avaya S8700 Multi-Connect only)	145
Testing terminating trunk transmission	146
Testing connectivity to the LAN	147

LED indicators	147
Telephone console LEDs	148
Attendant console LEDs	148
Terminal alarm notification	148
DS1 Converter circuit pack LEDs	148
SPAN LEDs	150
Index	151

Contents

Chapter 1: Introduction

This documentation, *Installing and Connecting the MDF and Telephones* provides procedures for installing Main Distribution Frames (MDF) and telephones. The procedures explain how you connect media gateways to the MDF and how to connect the MDF to the public switched telephone network (PSTN). This document also explains how to install and wire telephones.

The following information is included in this document:

- [Installing the main distribution frame](#) on page 13
- [Installing the patch panel](#) on page 29
- [Media gateway connections to the MDF](#) on page 33
- [Installing and wiring telephones and trunks](#) on page 69
- [Testing the complete configuration](#) on page 135

Audience

This documentation is for the following audiences:

- Trained field installation
- Technical support personnel
- Authorized Business Partners

How to use this documentation

Use this documentation as a guide to install and connect MDFs and telephones. For information about a particular task, use the index or table of contents to locate the page number where the information is described.

Perform tasks related to the Main Distribution Frame in the following sections as appropriate:

- [Installing the main distribution frame](#) on page 13
- [Installing the patch panel](#) on page 29. This chapter is only for customers using a patch panel rather than a main distribution frame (typically smaller installations).
- [Media gateway connections to the MDF](#) on page 33
- [MDF connections to stations and the public switched telephone network](#) on page 41

Introduction

Connect the necessary telephone, trunking, and peripheral equipment using the information in [Installing and wiring telephones and trunks](#) on page 69 and [Installing and wiring telephone power supplies](#) on page 109.

Complete the installation using information in the following section:

- [Testing the complete configuration](#) on page 135

Downloading this book and updates from the Web

You can download the latest version of this documentation from the Avaya Support Web site (<http://support.avaya.com>). You must have access to the Internet and a copy of Adobe Reader installed on your personal computer.

Avaya makes every effort to ensure that the information in this book is complete and accurate. However, information can change after we publish this documentation. Therefore, the Avaya Support Web site might also contain new product information and updates to the information in this book. You can also download these updates from the Avaya Support Web site.

To view any book, you must have a copy of Adobe Acrobat Reader.

Note:

If you do not have Acrobat Reader, you can get a free copy at <http://www.adobe.com>.

To download an electronic version of this documentation:

1. Access the Avaya Support Web site at <http://support.avaya.com>.
2. At the top of the page, click in the **Search** text box.
3. Type the documentation number 03-300686 and click the arrow button.
4. In the resulting list, locate the latest version of the document, and then click the document title to view the latest version of the book.

Sending us comments

Avaya welcomes your comments about this book. To reach us by:

- Mail, send your comments to:
Avaya Inc.
Product Documentation Group
Room B3-H13
1300 W. 120th Ave.
Westminster, CO 80234 USA
- E-mail, send your comments to:
document@avaya.com
- Fax, send your comments to:
1-303-538-1741

When commenting, be sure that you mention the name and number of this book, *Installing and Connecting the MDF and Telephones* (03-300686).

Related resources

You may need the information in the following documents to perform a complete installation. These documents are included on the CD-ROM *Documentation for Avaya Communication Manager, Media Gateways and Servers*, (03-300151). You can download the contents of this CD-ROM from the Avaya Support Web site, <http://support.avaya.com>.

- *Installing the Avaya G650 Media Gateway*, 03-300685. Provides procedures for installing and cabling a G650 Media Gateway, connecting to the customer's network, and testing the complete configuration.
- *Adding New Hardware for Avaya Servers and Gateways* (03-300684). Provides information on installing adjunct and peripheral equipment that an S8400, S8500, or S8700-series Server supports.
- *Electronic Preinstallation Worksheet (EPW)*. An Excel spreadsheet that provides the customer network information that you need to configure the control network components with the Avaya Installation Wizard. Get the completed EPW from the Avaya project manager, Avaya software technician, or customer network administrator. A blank EPW is available at the AIW Web site, <http://support.avaya.com/avayaiw>.
- *Administrator Guide for Avaya Communication Manager*, (03-300509). Provides user information on how to administer trunks and telephones.

Introduction

- *Maintenance Commands for Avaya Communication Manager 5.0, Media Gateways and Servers*, (03-300431). Provides information on how to use command interfaces, command syntax, and output from maintenance-related commands.
- *Maintenance Alarms for Avaya Communication Manager 5.0, Media Gateways and Servers*, (03-300430). Provides information on how to use alarms, error codes, and tests to diagnose and repair problems.
- *Maintenance Procedures for Avaya Communication Manager 5.0, Media Gateways and Servers* (03-300432). Provides information on how to troubleshoot and replace various components.
- The following job aids are also available on the CD-ROM *Documentation for Avaya Communication Manager, Media Gateways and Servers*:
 - *Approved Grounds*. Provides a description of all approved grounds.
 - *Connector and Cable Diagrams (Pinout Charts)*. Provides pinout information for various components.
 - *Option Switch Settings*. Provides settings for various components.

For all documents associated with the S8400, S8500, S8700-series Server, see the CD titled *Documentation for Avaya Communication Manager, Media Gateways and Servers* (03-300151).

Chapter 2: Installing the main distribution frame

If the equipment room does not have one, you must build a main distribution frame (MDF) that connects the media gateways to the building phone network and to the public switched telephone network (PSTN). The tasks include the following:

- [Physical requirements and layout](#) on page 13
- [Main distribution frame hardware installation](#) on page 17

If the installation will use a patch panel rather than a main distribution frame, use the procedures in [Chapter 3: Installing the patch panel](#) on page 29.

Physical requirements and layout

Before installing the MDF and other equipment in the equipment room, ensure that there is adequate space and there is a plan for placing the equipment.

Installation space requirements

Make sure there is adequate space for the following pieces of equipment:

- [Sneak fuse panels and emergency transfer units](#) on page 13
- [110-type hardware](#) on page 13
- [Cable Slack Manager](#) on page 14

Sneak fuse panels and emergency transfer units

You need about 8 inches (20 centimeters) of horizontal wall space for each column of sneak fuse panels. Horizontal wall space must also be provided for emergency transfer units.

110-type hardware

The trunk/auxiliary field and the distribution field are mounted on the same wall. Each 110P-type terminal block is 8.5 inches (21.6 centimeters) wide. Vertical patch cord troughs are 5.31 inches (13.4 centimeters) wide and horizontal patch cord troughs are 23 inches (58.4 centimeters) wide.

Each 110A-type terminal block is 10.8 inches (27.4 centimeters) wide; however, no horizontal patch cord troughs are used and the blocks are shorter than 110P-type terminal blocks. This allows the 110A-type terminal blocks to be stacked. Therefore, the 110A-type hardware requires less space than the 110P-type hardware on a per-station basis.

Cable Slack Manager

A Cable Slack Manager is 32 inches (81.3 centimeters) wide. Slack managers are commonly used in installations consisting of media gateway stacks, such as the SCC1 Media Gateways. Determine the quantity of slack managers by dividing the total length of the MDF in inches (centimeters) by 32 (81.3). A partial number of 0.4 or less should be rounded down, and a partial number of 0.5 or more should be rounded up (for example: 2.4 = two Cable Slack Managers and 2.5 = three Cable Slack Managers).

Note:

Cable clamps are required in installations with Cable Slack Managers. At the rear of the media gateways, on each rear ground plate, install two cable clamps using the screws provided. These clamps hold the 25-pair input/output or MDF cables in place.

Installation layout

Make sure you review the following information:

- [Information outlet locations](#) on page 14
- [Site, satellite, and adapter locations](#) on page 14
- [Sizing 4-pair station cables](#) on page 15
- [Sizing 25-pair and multiple 25-pair station cables](#) on page 15
- [3-pair station cable circuits](#) on page 15
- [4-pair station cable circuits](#) on page 15

Information outlet locations

The customer or marketing representative must provide floor plans showing the information outlet locations and types (flush- or surface-mounted) required. The floor plans must also show a complete overview of all conduit and cabling facilities in the building.

Site, satellite, and adapter locations

Use the following information when determining site, satellite, or adapter locations.

- Keep the number of locations to a minimum.
- To minimize the station wiring distances, centrally locate the sites/satellites, or adapters among the information outlets.
- Site/satellite locations must be easily accessible and contain AC-powered receptacles.

One 258A/BR2580A adapter is required for each 25-pair station cable containing 4-pair station circuits. One 356A adapter is required for each 25-pair station cable containing 3-pair station circuits. Hardware requirements are the same as for the equipment room.

Sizing 4-pair station cables

Use the scale of the floor plan to determine the approximate length of the station cables required per the standard SYSTIMAX wiring concepts.

Sizing 25-pair and multiple 25-pair station cables

Use the scale of the floor plan to determine the approximate length of each 25-pair station cable. The cables must be selected and properly sized to make maximum use of the hardware at the equipment room or satellite location.

Use 25-pair B25A cables to connect adapters directly to the MDF or satellite location. Staggered-finger cables, equipped with factory-installed 25-pair connectors at both ends, should be used when multiple 25-pair cables are used between the equipment room or satellite location and the adapters. B25A cables are required at the equipment room or satellite location to connect the staggered-finger cables to the 110-type terminal blocks.

Use the following information to determine the cable size (cable pairs) required for either 3-pair or 4-pair circuits. Note the length and size on the floor plan to aid in the ordering and installation of the station cables.

3-pair station cable circuits

To determine the size of station cables containing 3-pair circuits, multiply the number of 3-pair circuits required at the satellite location by 3.5. Then, using the minimum size cable requirement, round up the cable size requirement to the next highest available cable bundle size. This will provide additional pairs for growth and compensate for every twenty-fifth pair in a cable that is not used.

4-pair station cable circuits

To determine the size of station cables containing 4-pair circuits, find out how many information outlets are served by the equipment room MDF or satellite location MDF. Multiply the number of information outlets by 4. Then, using the minimum size cable requirement, round up the cable size requirement to the next highest available cable bundle size.

Note:

This formula may not compensate for the unused 25th pair in all cases. If not, it must be allowed for.

Main distribution frame cross-connect fields

Each main distribution frame (MDF) contains a trunk/auxiliary field and a distribution field. The trunk/auxiliary field contains three cross-connect areas:

- *The green field* terminates the network interface leads from the central office (CO) and provides the terminals to cross-connect the leads to the purple or yellow fields as required. A single row of the 110-type terminal block can terminate 24 1-pair, 8 3-pair, or 12 2-pair trunks.
- *The purple field* terminates the trunk circuits from the media gateway with WP-90929, List 1 or 3 concentrator cables. Also, 25-pair cables can be used to terminate trunk circuits from the media gateway with each trunk circuit pack connecting to one 25-pair row of the 110-type terminal block. Each terminal block row can terminate 24 1-pair, 8 3-pair, or 12 2-pair trunks.
- *The yellow field* provides cross-connect terminals for all miscellaneous leads from the media gateway, such as alarm monitors, emergency transfer relay power, and attendant console power. This field is used for emergency transfer wiring, paging equipment, music sources, and so forth.

The distribution field contains four cross-connect areas:

- *The purple field* (port field) terminates 25-pair cables from the media gateway. Each line circuit pack connects to one 25-pair row of the 110-type terminal block. One 25-pair cable is required for each line circuit pack.

Note:

The TN2183 16-port Analog Line circuit pack requires an adapter cable to connect from one connector on the media gateway to two 25-pair connectors on a terminal block. *The yellow field* (auxiliary field) terminates all 25-pair cables from the auxiliary cabinet (if used). The yellow field is located in the lower right-hand corner of the distribution field.

- *The white field* (station field) terminates the station wiring. The white field indicates 3-pair station circuits (eight circuits per 25-pair cable) routed through a satellite closet.
- *The blue field* (station field) also terminates station wiring. The blue field indicates 3- and/or 4-pair station circuits (eight or six circuits, respectively, per 25-pair cable). The fourth pair, of the 4-pair station circuit provides adjunct power from the cross-connect field on an as-needed basis to telephones and consoles within 250 feet (76 meters) of the MDF.

Main distribution frame hardware installation

This section provides information on installing a main distribution frame (MDF) in an equipment room. It must be installed before connecting media gateways to it and before connecting it to the public switched telephone network (PSTN) outside the building and stations within the building.

SYSTIMAX 110-type hardware is used for the MDF. 110-type hardware is available in two basic types: the 110A and 110P. The 110A requires less wall space than the 110P. The 110P includes horizontal and vertical cable troughs for managing cross-connect cables. The media gateways are connected to the MDF with the supplied B25A male to female 25-pair cables. The cables are provided in 10-foot (3 meter) and 15-foot (4.5 meter) lengths.

[Figure 1: Example MDF connections \(MCC1 Media Gateway\)](#) shows the cross-connections for common circuit packs. See this figure when cross-connecting wire pairs to the MDF.

Figure 1: Example MDF connections (MCC1 Media Gateway)

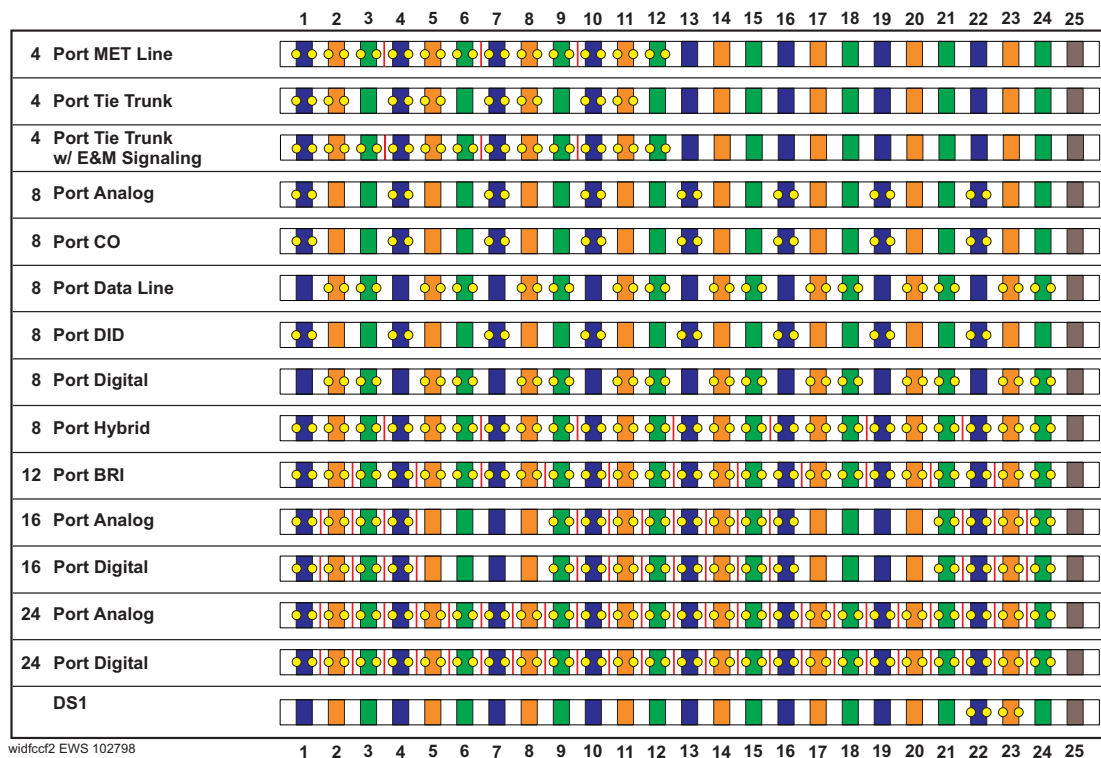

[Figure 2: Example MDF connections \(G650 Media Gateway\)](#) on page 18 shows a detailed example of the G600 Media Gateway cables connecting media gateways and satellite closets to the MDF. This figure shows the cross-connections for one example station circuit.

Figure 2: Example MDF connections (G650 Media Gateway)

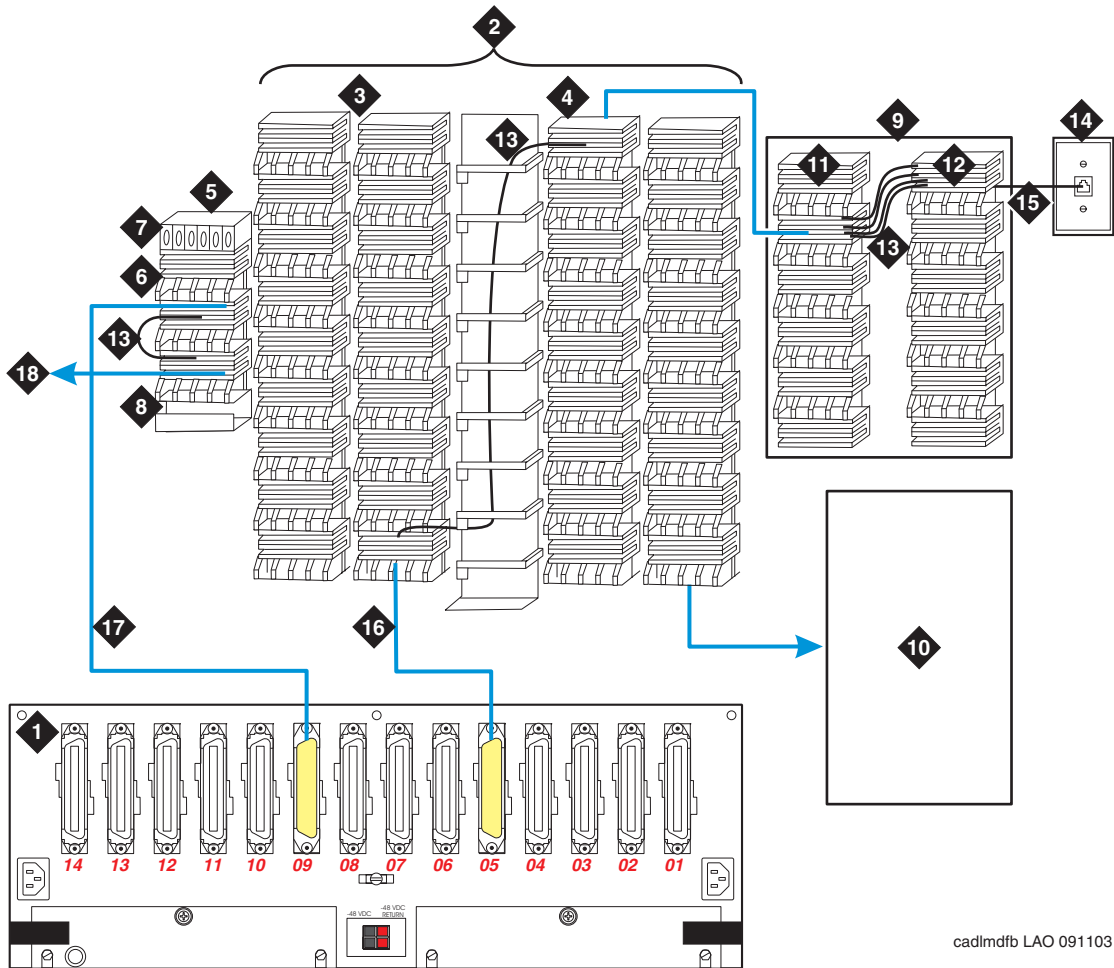

cadlmdfb LAO 091103

Figure notes:

- | | |
|---|--------------------------------------|
| 1. Rear of Media Gateway | 10. Auxiliary Cabinet (Yellow Field) |
| 2. Main Distribution Frame (MDF) | 11. White Field |
| 3. Port Distribution Field (Purple Field) | 12. Blue Field |
| 4. Station Distribution Field (White Field) | 13. Cross-Connect Jumpers |
| 5. Trunk/Auxiliary Field | 14. 103A or Modular Wall Jack |
| 6. Purple Field | 15. 4-Pair Line Cord |
| 7. Yellow Field | 16. To Line Circuit Pack |
| 8. Green Field | 17. To Trunk Circuit Pack |
| 9. Satellite Closet | 18. To Network Interface |

Main distribution frame placement

The preferred location of the MDF is directly behind the media gateways.

[Figure 3: Typical 110A-type terminal blocks \(G650 Media Gateway\)](#) shows a typical installation using 110A-type terminal blocks.

Figure 3: Typical 110A-type terminal blocks (G650 Media Gateway)

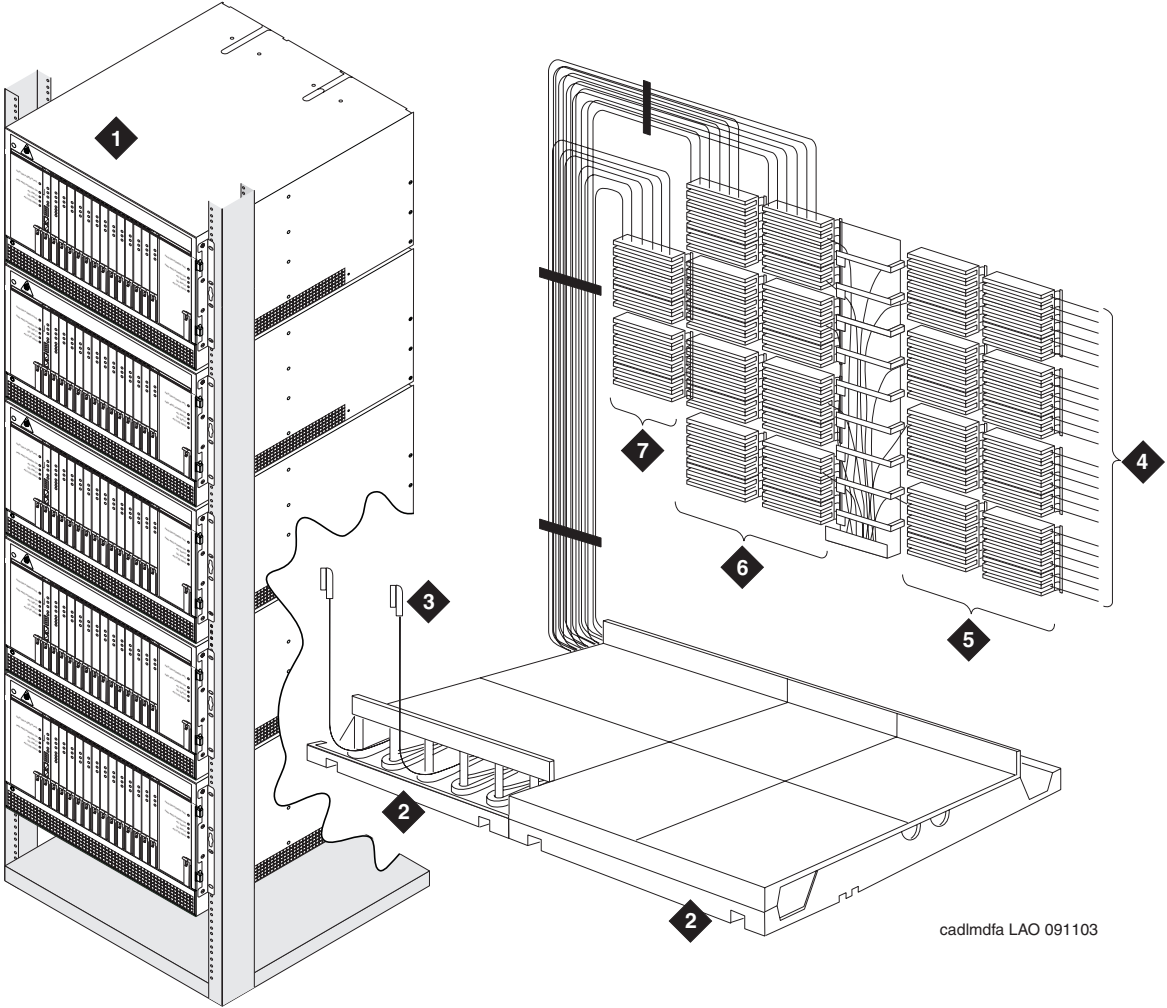

Figure notes:

- 1. G600 Media Gateways in rack
- 2. Z113A Cable Slack Manager
- 3. 25-Pair Cable to Media Gateway
- 4. Station Cables
- 5. Station Distribution Field
- 6. Port Distribution Field
- 7. Trunk/Auxiliary Field

Main distribution frame labels

[Figure 4: Label graphic symbols and nomenclature](#) on page 20 shows the graphic symbols used on labels for the media gateways, cross-connections, information outlets, and cables. The labels are color-coded to identify media gateway wiring:

- Green — To central office (CO)
- Purple — To media gateway ports
- Yellow — To auxiliary equipment and miscellaneous media gateway leads
- Blue — To information outlets
- White — From MDF to satellite locations (3-pair)

Each label identifies two rows on the terminal block. The upper half identifies the row above it and the lower half identifies the row below it. The labels are inserted into the clear plastic designation strips furnished with the terminal blocks. The strip is snapped in place between the terminal block rows. Label code number 1220A (comcode 103970000) contains all of the required labels.

Figure 4: Label graphic symbols and nomenclature

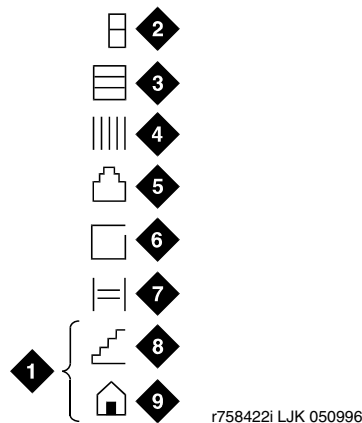

Figure notes:

- | | |
|---|--------------------------|
| 1. Floor or Building Identification (write as required) | 5. Information Outlet |
| 2. Media Gateway | 6. Site/Satellite Closet |
| 3. Carrier (leave blank for G600 Media Gateway) | 7. Tie Circuit |
| 4. Slot | 8. Floor |
| | 9. Building |

Mounting 110A- or 110P-type terminal blocks on the wall

The 110A-type terminal blocks can be stacked in almost any arrangement at any height or location on the wall. [Figure 5: 110A-type terminal blocks \(300-pair\)](#) on page 22 shows one arrangement. The distance between the mounting screw holes on the terminal blocks is 10.8 inches (27.4 centimeters). If a vertical patch cord trough is used, the distance between the mounting screw holes is 5.31 inches (13.3 centimeters).

With 110P-type terminal blocks, the first block of the trunk/auxiliary field is aligned with the left side of the media gateway. See [Figure 6: 110P-type terminal blocks \(900-pair\)](#) on page 23. This arrangement allows for growth on the right side of the MDF.

To mount 110A- or 110P-type terminal blocks:

1. Route the cables from the rear of the media gateway stack to the MDF via the Cable Slack Manager. See [Installing Cable Slack Managers](#) on page 25.
2. If you are installing 300-pair terminal blocks, draw a level horizontal line on the wall 47.5 inches (1.2 meters) above the floor. See [Figure 5: 110A-type terminal blocks \(300-pair\)](#) on page 22.

If you are installing 900-pair terminal blocks, draw a level horizontal line on the wall 23 inches (58.4 cm) above the floor. See [Figure 6: 110P-type terminal blocks \(900-pair\)](#) on page 23.

3. To mount the first trunk/auxiliary field terminal block, partially install 2 3/4-inch, #12 wood screws, 7-11/16-inch (19.5-centimeter) apart on the left side of the horizontal line on the wall.
4. Slide the bottom terminal block fit onto the mounting screws and mark the upper mounting screw locations.
5. Remove the terminal block and partially install the upper mounting screws.
6. Place the terminal block on the mounting screws and tighten the screws.
7. If installing a vertical patch cord trough, partially install the first screw for the patch cord trough, on the line, 7/8-inch (2.2-centimeter) to the right of the previous screw. Partially install the second mounting screw 5.31 inch (13.5 centimeter) to the right of the screw just installed. Repeat Steps 4, 5, and 6.
8. If another trunk/auxiliary field terminal block is to be installed, partially install the first screw for the terminal block, on the line, 7/8-inch (2.2-centimeter) to the right of the previous screw. Partially install the second mounting screw 7-11/16-inch (19.5-centimeter) to the right of the screw just installed. Repeat Steps 4, 5, and 6.
9. If a horizontal patch cord trough is to be installed, install it, on the line, between the trunk/auxiliary field and the distribution field.
10. To install the first distribution field terminal block, partially install 2 3/4-inch, #12 wood screws, 7-11/16 inch (19.5 centimeter) apart on the line, to the right of the vertical patch cord trough. Repeat Steps 4, 5, and 6.

Installing the main distribution frame

11. If installing another distribution field terminal block, partially install the first screw for the terminal block, on the line, 7/8-inch (2.2 centimeter) to the right of the previous screw. Partially install the second mounting screw 7-11/16 inch (19.5 centimeter) to right of the screw just installed. Repeat Steps 4, 5, and 6.
12. If installing a vertical patch cord trough in the distribution field, repeat Step 6.
13. Repeat Steps 11 and 12 until all the terminal blocks and vertical patch cord troughs in the distribution field are installed.

Figure 5: 110A-type terminal blocks (300-pair)

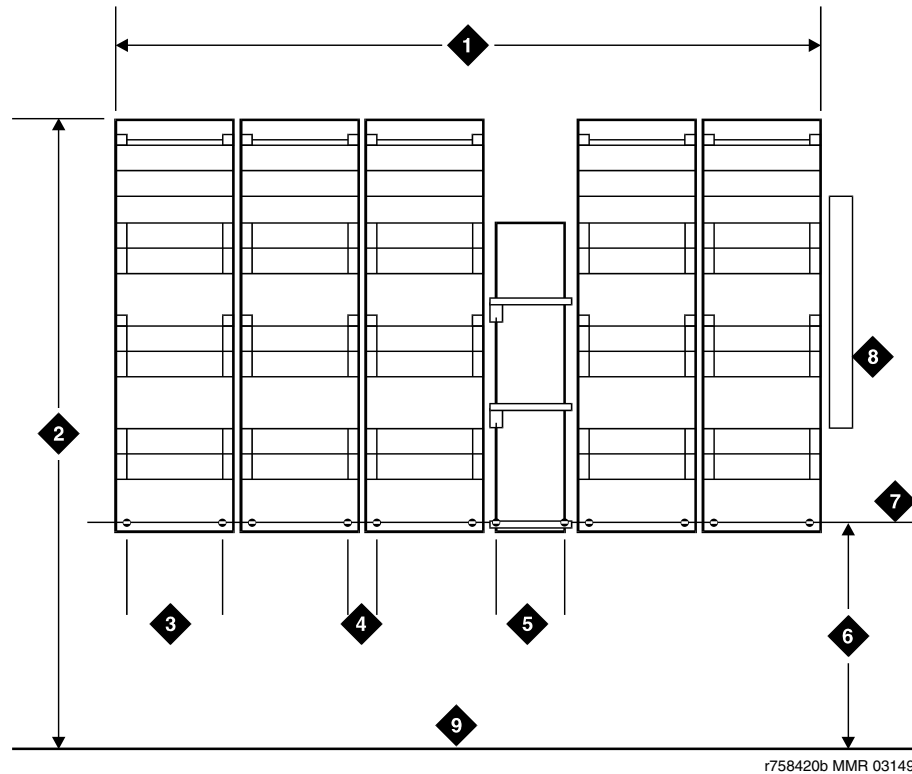

Figure notes:

- | | |
|-----------------------------------|------------------------------------|
| 1. 4 feet (1.22 meters) | 6. 47.5 inches (120.6 centimeters) |
| 2. 6.6 feet (2 meters) | 7. Horizontal Line |
| 3. 7.68 inches (19.5 centimeters) | 8. AC Power Strip |
| 4. 7/8-inch (2.22 centimeters) | 9. Floor Line |
| 5. 5.31 inches (13.5 centimeters) | |

Figure 6: 110P-type terminal blocks (900-pair)

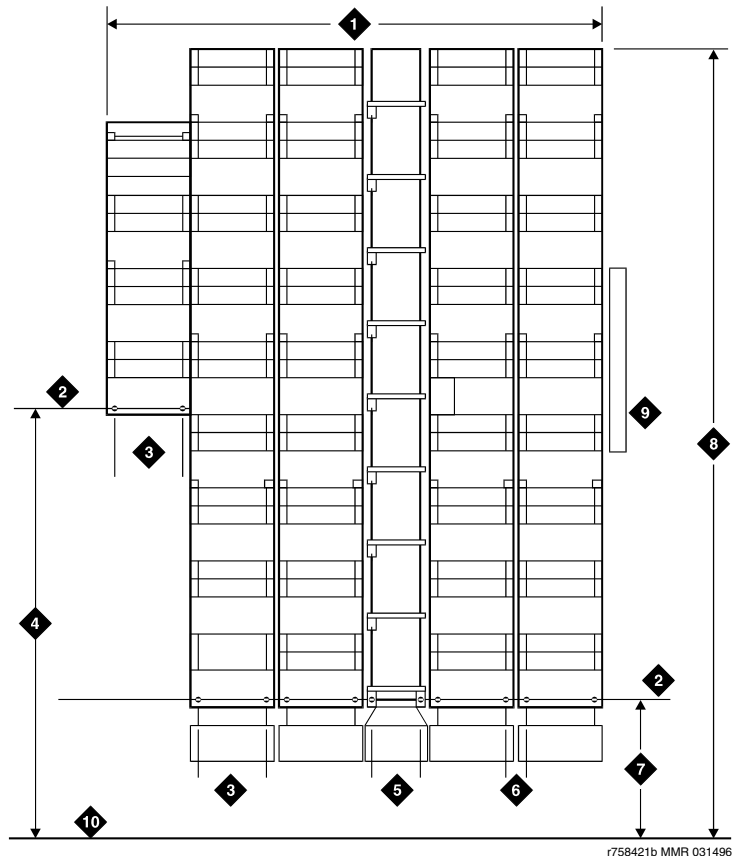

Figure notes:

- | | |
|------------------------------------|---------------------------------|
| 1. 4 feet (1.22 meters) | 6. 7/8-inch (2.22 centimeters) |
| 2. Horizontal Line | 7. 23 inches (58.4 centimeters) |
| 3. 7.68 inches (19.5 centimeters) | 8. 8 feet (2.43 meters) |
| 4. 47.5 inches (120.6 centimeters) | 9. AC Power Strip |
| 5. 5.31 inches (13.5 centimeters) | 10. Floor Line |

Mounting 110P-type terminal blocks on a frame

The 900-pair 110P-type terminal blocks and the associated patch cord troughs can also be mounted on a free-standing, floor-mounted 1110A2 Apparatus Mounting Frame. See [Figure 7: 1110A2 and 1110C1 apparatus mountings](#) on page 24.

Each 1110A2 provides the space to mount five terminal blocks/patch cord troughs on each side of the frame. A cable support structure, apparatus mounting 1110C1, mounts directly on top of the 1110A2 and provides support for all cables routed to and from the frame. See [Table 1: Apparatus mounting frame ordering information](#) on page 25.

Figure 7: 1110A2 and 1110C1 apparatus mountings

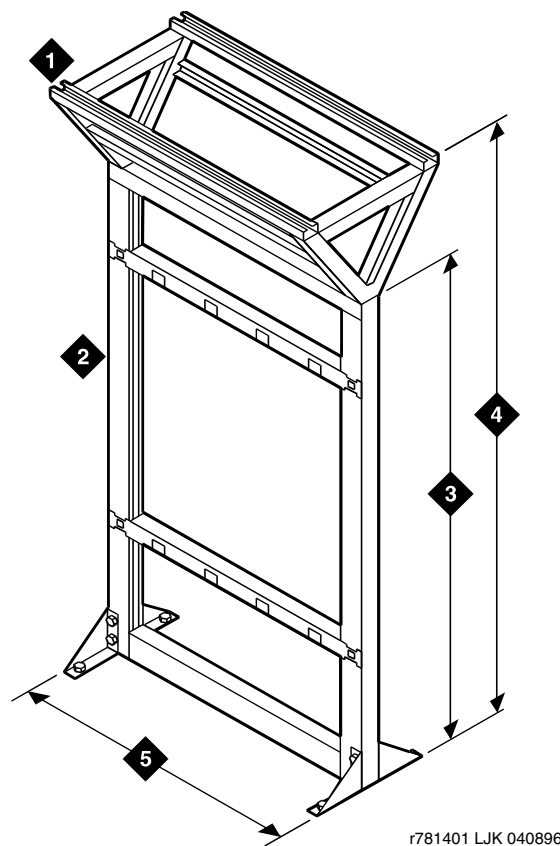

Figure notes:

- | | |
|--------------------------------|------------------------------------|
| 1. 1110C1 Apparatus Mounting | 4. 88.5 inches (225 centimeters) |
| 2. 1110A2 Apparatus Mounting | 5. 43.5 inches (110.5 centimeters) |
| 3. 76 inches (193 centimeters) | |
-

Table 1: Apparatus mounting frame ordering information

Code number	Description	Comcode
1110A2	Apparatus Mounting Frame	104032495
1110C1	Cable Support Assembly	104175120
1110A1	End Dress Panel	104176268
2110A1	Top Dress Panel	104176276
2110B1	Bottom Dress Panel	104176284

Installing Cable Slack Managers

Run excess cables on an upper cable ladder (if the MDF connectors are on top) or route them through a cable slack manager that is placed next to the MDF.

To install cable slack managers:

1. Place the Z113A Cable Slack Manager against the wall under the MDF. See [Figure 9: Cable routing through Cable Slack Manager—example for SCC1 Media Gateway](#) on page 27. Align the left side of the cable slack manager with the first terminal block of the trunk/auxiliary field.
2. Place the next cable slack manager beside the previously installed unit. Align the tabs and interlocks and snap the units together.
3. Repeat Step 2 until all cable slack managers are installed.

Note:

Nine 1/4-inch (0.63 centimeter) holes are provided in a cable slack manager base if earthquake mounting is required. If a base is mounted on an uneven floor, shims may be required for leveling and to assure proper fit of the covers.

Holes are provided in the sides of the base for bolting cable slack manager together. Obtain bolts and shims locally.

4. An example of how the media gateway cables route through the cable slack manager is shown in [Figure 8: Cable routing through Cable Slack Manager—example for MCC1 Media Gateway](#) on page 26.

Installing the main distribution frame

Cable clamps are required in installations with cable slack managers. At the rear of the media gateways, install two cable clamps using the screws provided. These clamps hold the 25-pair input/output or MDF cables in place. [Figure 8: Cable routing through Cable Slack Manager—example for MCC1 Media Gateway](#) on page 26 and [Figure 9: Cable routing through Cable Slack Manager—example for SCC1 Media Gateway](#) on page 27 show cable clamp placement and cable routing.

Figure 8: Cable routing through Cable Slack Manager—example for MCC1 Media Gateway

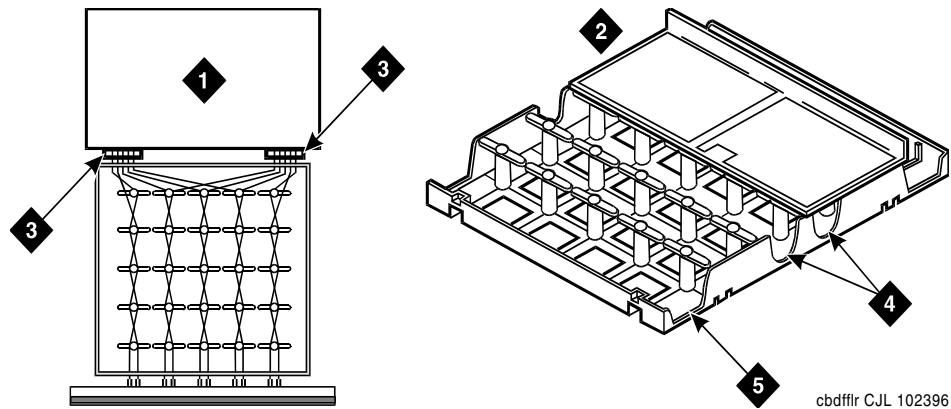
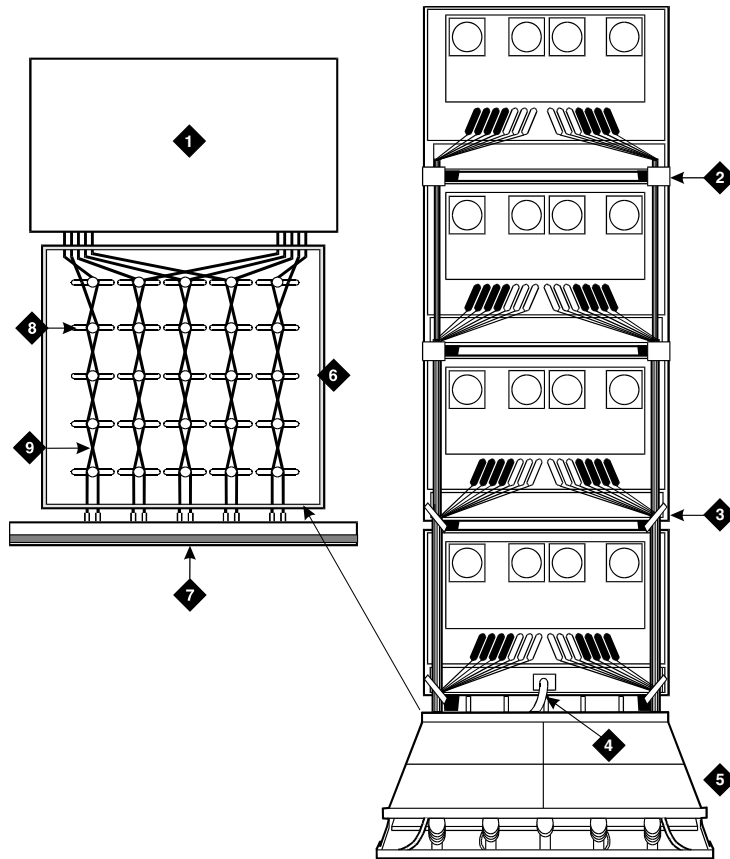

Figure notes:

- | | |
|-------------------------|---|
| 1. Top of Media Gateway | 4. Spare Center Troughs |
| 2. Cable Slack Manager | 5. Media Gateway Trough for Port Cables |
| 3. Cable Clamp | |

Figure 9: Cable routing through Cable Slack Manager—example for SCC1 Media Gateway



r758155 CJL 031496

Figure notes:

- | | |
|--------------------------|--|
| 1. Top of Media Gateways | 6. Cable Slack Manager (Cover Removed) |
| 2. Cable Clamps | 7. Main Distribution Frame (MDF) |
| 3. Cable Ties (Optional) | 8. Route Cables Along Path Shown |
| 4. Power Cord | 9. Port Cables |
| 5. Cable Slack Manager | |

Installing the main distribution frame

Chapter 3: Installing the patch panel

Installing patch panels

This chapter is for installations using a patch panel rather than a main distribution frame for connections to the building phone network and the public switched telephone network (PSTN). Patch panels are arrays of RJ45 jacks and associated B25A cables. The panels accommodate 2-wire, 24-port DCP/analog port boards and 8-port analog trunk boards. The panels are mounted either below or above the media gateway stack. You cannot mount patch panels in between media gateways.

Note:

You do not have to mount the patch panels in the same rack as the media gateways. You can mount the panels in telephone closets as appropriate.

For more information, see [Figure 10: Typical RMC patch panel installation](#) on page 30 while you perform this procedure.

To install patch panels:

1. Use the supplied mounting screws to mount the patch panels on the rack below media gateway A or above the topmost media gateway.
2. Attach B25A cables to the patch panels and the circuit pack amphenol connectors.

Note:

Connect 24-port DCP or analog circuit packs to the 24-port patch panels.

Note:

Connect 8-port analog trunk, “combo,” or DID trunk circuit packs to either of the first two banks on the 8-port patch panel. If an TN2185B ISDN-BRI S/T-TE Interface (4-wire, 8 ports) circuit pack is present, connect that circuit pack to the third bank on the 8-port patch panel.

Cross-connecting the media gateway to the patch panels

Cross-connect the port circuit packs to the G650 Media Gateway patch panels or other standard 110A cross-connect equipment ([Figure 11: Sample cross-connect field patch panel connections](#) on page 31).

Figure 10: Typical RMC patch panel installation

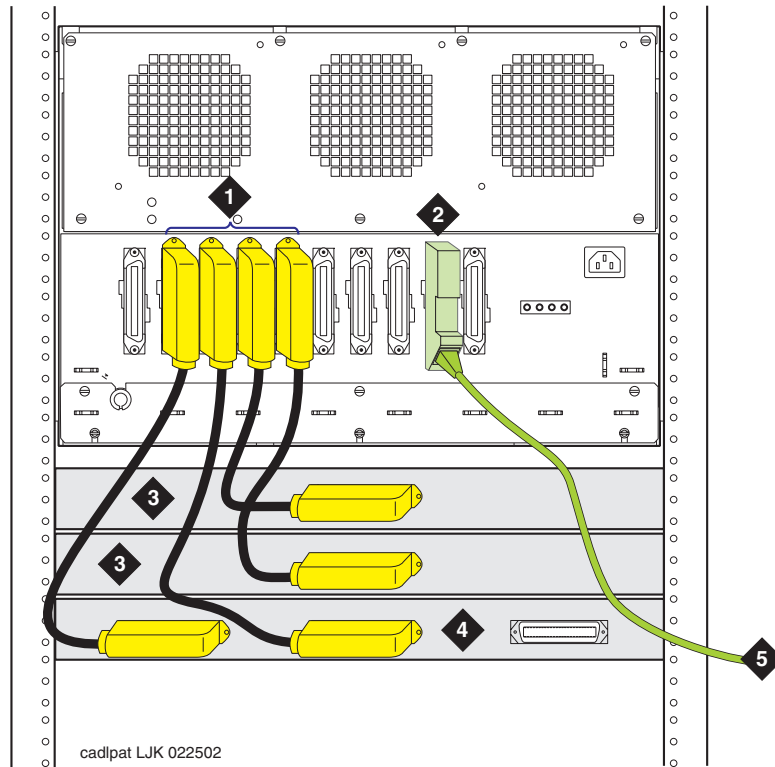
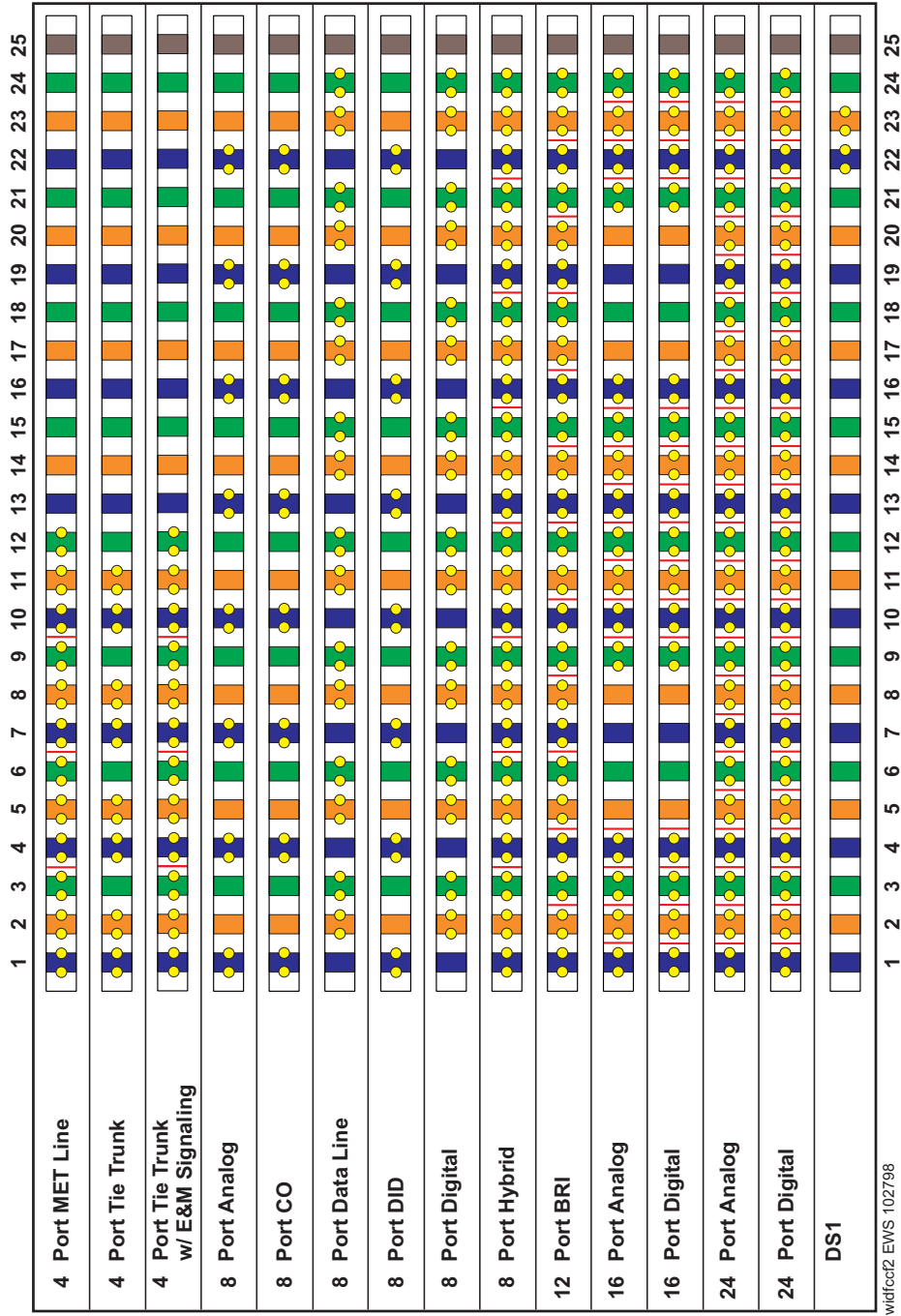

Figure notes:

- | | |
|---|-------------------------|
| 1. Circuit pack amphenol connectors and B25A cables | 3. 24-port patch panels |
| 2. IP server interface adapter and green CAT5 cable | 4. 8-port patch panel |
| | 5. To network |

Figure 11: Sample cross-connect field patch panel connections



Installing the patch panel

Chapter 4: Media gateway connections to the MDF

Once the main distribution frame (MDF) is installed and wired, you must connect the media gateways to the MDF.

Run excess cables on an upper cable ladder (if the MDF connectors are on top) or route them through a cable slack manager that is placed next to the MDF. For more information, see [Installing Cable Slack Managers](#) on page 25.

This section has information about

- [Equipment room cabling labels](#) on page 33
- [Cable routing guidelines](#) on page 36
- [Trunk cables among network interface, sneak fuse panel, and media gateway](#) on page 38

And procedures for:

- [Installing cables between media gateway and MDF](#) on page 38
- [Installing connector cables between auxiliary cabinet and MDF](#) on page 39

Equipment room cabling labels

The purple port label shown in [Figure 12: Equipment room cabling labels](#) on page 34 is installed on both ends of the 25-pair cables connecting to the trunk/auxiliary field and/or distribution field.

Figure 12: Equipment room cabling labels

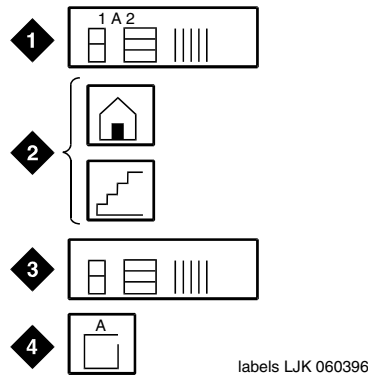

Figure notes:

- 1. Purple Label (Port Cable)
- 2. Blue/Yellow Label (Building and Floor)
- 3. Yellow Label (Auxiliary)
- 4. Blue/Yellow Label (Site or Satellite)

The top blue/yellow building and floor labels are for cables connecting from the equipment room to a site/satellite location on another floor or in another building. The yellow label is for auxiliary circuits connecting to the trunk/auxiliary field. The bottom blue/yellow label is for 25-pair cables connecting to site/satellite closets. See [Table 2: Equipment room labels](#).

Table 2: Equipment room labels

Label name	Range
Port Cable	1A1-1A20, 1B1-1B20, 1C1-1C20, 1D1-1D20, 1E1-1E20
Building	Field Identified
Floor	Field Identified
Auxiliary Cable	Field Identified
Site or Satellite	A-F and/or Field Identified

[Figure 12: Equipment room cabling labels](#) on page 34 details the label name and range of each label. [Table 3: Cable/connector/building label ordering information](#) provides label ordering information.

Table 3: Cable/connector/building label ordering information

Description	Quantity	Comcode
201A Labels	34 Sheets	103969994

[Figure 13: Self-stick label on 25-pair cable connector](#) shows the proper way to install a label on a 25-pair cable connector. Install the label near the rear of the connector so it is not obscured by the media gateway connector retainers. It can also be installed on the skin of the cable near the connector.

Figure 13: Self-stick label on 25-pair cable connector

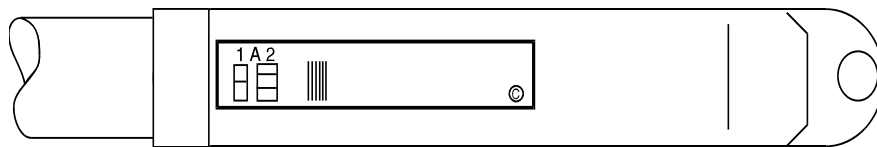

lbd25p LJK 101596

Cable routing guidelines

[Figure 14: Cable routing to top terminal blocks](#) and [Figure 15: Cable routing to bottom terminal blocks](#) on page 37 show typical cable routing from the media gateway to the top and bottom of the MDF, respectively.

Figure 14: Cable routing to top terminal blocks

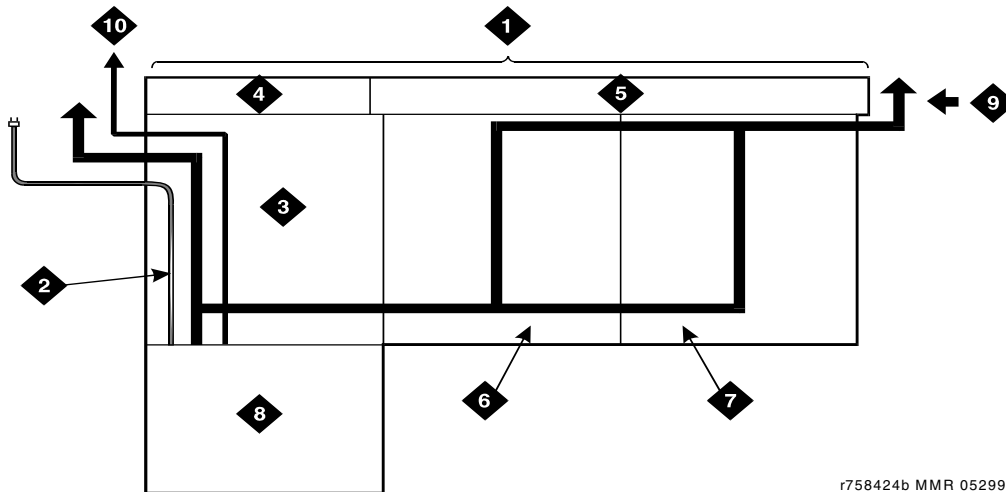

r758424b MMR 052996

Figure notes:

- | | |
|---|---|
| 1. Main Distribution Frame | 6. Cable Slack Manager Number 2 |
| 2. AC Power Cord (AC-powered media gateways only) | 7. Cable Slack Manager Number 3 |
| 3. Cable Slack Manager Number 1 | 8. Media Gateway(s) |
| 4. Trunk/Auxiliary Field | 9. To Building Cables |
| 5. Station Distribution Field | 10. 10 AWG (#25) (6 square millimeters) Wire to Coupled Bonding Conductor |

Figure 15: Cable routing to bottom terminal blocks

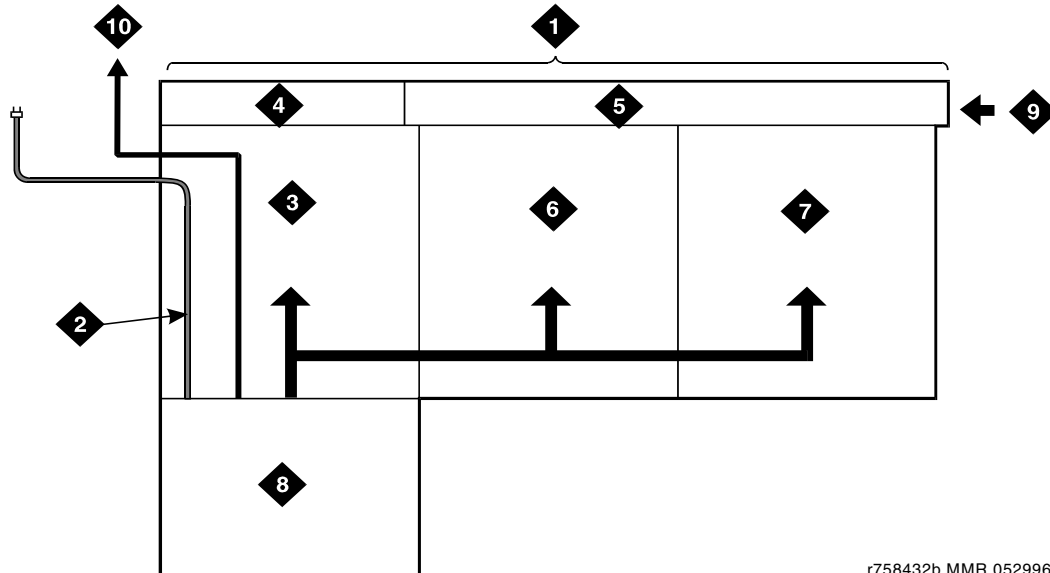

r758432b MMR 052996

Figure notes:

- | | |
|---|---|
| 1. Main Distribution Frame | 6. Cable Slack Manager Number 2 |
| 2. AC Power Cord (AC-powered media gateways only) | 7. Cable Slack Manager Number 3 |
| 3. Cable Slack Manager Number 1 | 8. Media Gateway(s) |
| 4. Trunk/Auxiliary Field | 9. Building Cables (through cable trough) |
| 5. Station Distribution Field | 10. 10 AWG (#25) (6 square millimeters) Wire to Coupled Bonding Conductor |

Use these guidelines when routing cables from the media gateway to the MDF. Following these guidelines will maximize use of the cable slack managers and make future cabling additions and changes easier.

- Connect each port cable at the media gateway, and then route it along the front trough of the cable slack manager to the connecting/terminal block, where the cable is terminated.
- Leave enough slack at the media gateway end of the cable to allow for proper dressing of the cables.
- Route the cable from the media gateway to the wall. Place the cable beside one of the rows of columns in the cable slack manager.

Note:

Retainers mounted on the columns keep the cable from protruding above the top of the base of the cable slack manager.

- Determine the length of the cable required to reach from the cable slack manager to the assigned connecting/terminal block.
- Use D rings on the wall to support the cable. (The cable must be supported.)

Media gateway connections to the MDF

- Coil the cable around the columns in the cable slack manager to store cable slack. The first run should always go across the full length of the 5 columns in the cable slack manager.
- Connect the cable to the assigned connecting/terminal block.
- Avoid placing copper cables where they may bend or strain fiber optic cables.

Trunk cables among network interface, sneak fuse panel, and media gateway

The 1-pair of central office (**CO**) trunks are installed by the network provider in the green field. Up to 24 pairs may be terminated on each row of the 110-type terminal block. Tie trunks also appear in the green field with up to eight 3-pair trunks terminated on each row of the 110-type terminal block.

WP-90929, List 1 and 3 concentrator cables can be used to connect the media gateway to the 110-type terminal blocks in the purple field. The 1-pair patch cords/jumper wires are then run from the purple terminal block rows to the green terminal block rows in order to establish the correct 3-pair modularity.

Installing cables between media gateway and MDF

To install cables between the media gateway and the MDF:

1. Install D rings on the wall between the cable slack manager and the terminal/connecting blocks mounted on the MDF.
2. Install a self-adhesive port label on the back of each connector on the connector cable. Position the labels so the media gateway connector retainers do not cover them.
3. At the rear of the media gateway, connect one end of the connector cable to the assigned connector.
4. Route the cable down the rear of the media gateway, through the cable slack manager, and to the MDF.
5. At the MDF, connect the other end of the cable to the assigned terminal/ connecting block connector.
6. Store the cable slack in the cable slack manager.
7. Repeat Steps 2 through 6 until all cables are installed.

Installing connector cables between auxiliary cabinet and MDF

Auxiliary equipment that connects to the MDF can be mounted inside the auxiliary cabinet. The equipment connects to an ED-1E1443-10 (Group 1) intraconnection panel mounted in the cabinet. This intraconnection panel consists of a 110-type 100-pair wiring block. Auxiliary equipment is connected to the 110-type wiring block. The wiring block is pre-wired to four 25-pair female connectors mounted on the outside rear of the cabinet.

To install connector cables between the auxiliary cabinet and the main distribution frame:

1. Install “D” rings on the wall between the cable slack manager and the terminal/connecting blocks mounted on the MDF.
2. Install a self-sticking port label on the rear of each connector on the B25A connector cable. See [Figure 16: Self-stick label on 25-pair cable connector](#) on page 39.
3. Labels should be positioned so the cabinet connector retainers do not obscure them.
4. At the rear of the auxiliary cabinet, connect 1 end of the connector cable to the assigned connector.
5. Route the cable down the rear of the cabinet and through the cable slack manager to the MDF.
6. At the MDF, connect the other end of the cable to the assigned terminal/connecting block connector.
7. Store the excess cable in the cable slack manager.
8. Repeat Steps 2 through 6 until all cables are installed.

Figure 16: Self-stick label on 25-pair cable connector

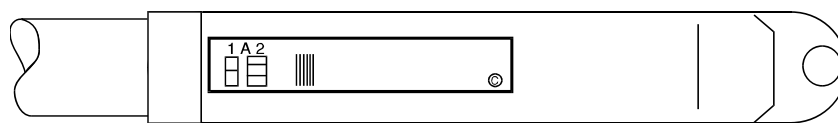

lbd25p LJK 101596

Chapter 5: MDF connections to stations and the public switched telephone network

Once the main distribution frame (MDF) is completed and the media gateways are connected to the MDF, you must connect the MDF to stations (telephones) and the public switched telephone network (PSTN). You must also have a provision plan at this time. For more information, see [Completing a provisioning plan](#) on page 52.

Station (telephone) wiring design

Station wiring from the MDF to information outlets are provided by various means. First, station cables are used to connect the MDF to satellite closets. Then station cables are used to branch out to site closet locations that are located physically close to information outlets.

Information outlets may be wired directly to the MDF, a satellite closet, or site closet.

The following hardware and cabling is used:

- [Information outlets](#) on page 41 (modular jacks)
- [Station cables](#) on page 42
- [Closets](#) on page 43
- [Station circuit distribution from equipment room](#) on page 44
- [Connected cable station adapters](#) on page 50

Information outlets

Information outlets are 8-pin modular jacks. Most of the outlets are wired with push-on connections. Information outlets are also available that connect to a double modular plug-ended 4-pair station cable routed from the MDF, a site/satellite location, or an adapter.

Station cables

For clarity a station cable is either a 25-pair cable, multiple 25-pair cable, or 4-pair D-inside wire (DIW) run from the equipment room, site/satellite location, or adapter to the information outlets. The following station cables are available. See [Figure 17: Example of extending 4-pair station cables](#) on page 43.

25-pair station cable — Use between the equipment room and site/ satellite locations or adapters. Use an A25D cable (male to male) between the equipment room and satellite closet. Use a B25A cable between the equipment room and site closet or adapter.

Multiple 25-pair station cable — Use between the equipment room and site/satellite locations or adapters. This cable consists of individually sheathed 25-pair cables with a factory-installed 25-pair connector on each end. Use a male-to-female cable to connect between the equipment room and site location or adapter. Use a male-to-male cable to connect between the equipment room and satellite location. Staggered finger cables are recommended for all multiple 25-pair station cables and are available in both double-ended and single-ended types.

Single modular plug-ended 4-pair station cable — Use this cable between adapters and information outlets that require push-on connections. It can also be used when 4-pair station cables are field-terminated on the 110-type terminal blocks in the equipment room or satellite closet and modularly connected to information outlets. The station cables are available in the following lengths:

- 10 feet (3.05 meters)
- 25 feet (7.62 meters)
- 50 feet (15.24 meters)
- 75 feet (22.86 meters)
- 100 feet (30.5 meters)
- 150 feet (45.72 meters)
- 200 feet (61 meters)

Note:

If more than 200 feet (61 meters) of 4-pair station cable is required, a 451A in-line adapter (double-ended modular female connector) is attached to the cable and a second 4-pair cable of the required length is plugged into the adapter. See [Figure 17: Example of extending 4-pair station cables](#) on page 43.

Double modular plug-ended 4-pair station cable — Use this cable to provide nonstandard length runs between adapters and information outlets with push-on connections. It can also be used between adapters and modularly connected information outlets. It is available in the same lengths as the single modular plug-ended cable.

Bulk Cable — Same as the 25-pair cable or multiple 25-pair cable; however, the bulk cable is not equipped with connectors. Use this cable between the equipment room and satellite closets when both are equipped with punch-down type terminal/connecting blocks.

4-pair station cable — Use this cable when 4-pair station cables are to be field-terminated on the 110-type terminal blocks in the equipment room or satellite closet and the information outlets require push-on connections.

Figure 17: Example of extending 4-pair station cables

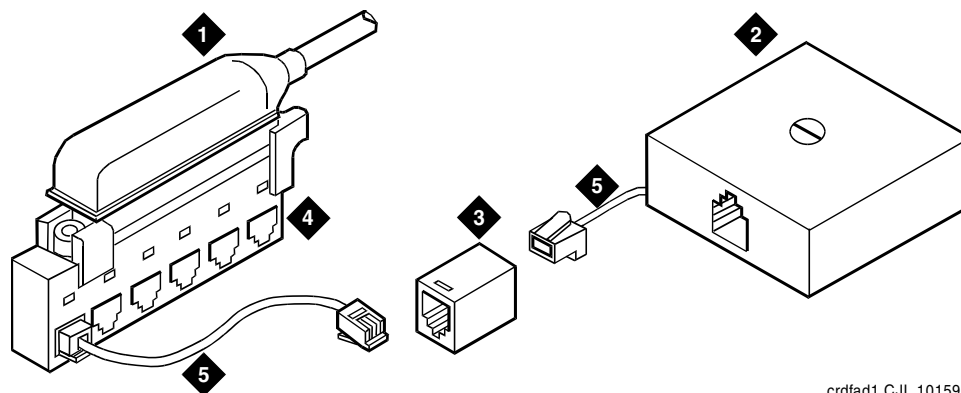

crdfad1 CJL 101596

Figure notes:

- | | |
|-------------------------|-------------------------|
| 1. Station Cable | 4. 258A Adapter |
| 2. Information Outlet | 5. 4-Pair Station Cable |
| 3. 451A In-Line Adapter | |

Closets

Closets are intermediate points between the Main Distribution Field and the endpoint. They are used to distribute wiring to multiple destinations via cross-connect equipment.

There are two different types of closet configurations. Satellite closets are usually distribution points for multiple site closets. However, information outlets may be wired directly to a satellite closet. Site closets are the last cross-connection point before the end user information outlet. Satellite and site closets may be used to apply bulk station power to information outlets.

Satellite locations

Satellite locations are closets that provide an administration point (using cross-connect equipment) for station cables and where adjunct power may be applied. The station cable circuits from the equipment room MDF are 3-pair. At the satellite location, 4-pair circuits run to the information outlets. The hardware used is 110-type terminal blocks.

Satellite locations using 110-type hardware

Each terminal block has a 3-pair (white field) and a 4-pair (blue field) located on the same terminal block.

The 110A-type terminal block that can be used is the 110AE1-75FT. It must be field-terminated to both the white and blue fields.

The 300-pair 110P-type terminal blocks that can be used are:

- 110PE1-300CT/FT — 25-pair connector on the white field and field-terminated on the blue field
- 110PE1-300FT — Field-terminated on both the white and blue fields

The 900-pair 110P-type terminal blocks that can be used are:

- 110PE1-900CT/FT — 25-pair connector on the white field and field-terminated on the blue field
- 110PE1-900FT — Field-terminated on both the white and blue fields

Site locations

Site locations are closets that provide a point in the station wiring for the administration of remote powering. Adapters are used at site locations to terminate the 25-pair station cables and provide connection points (modular jacks) for power adapters and 4-pair station cables.

The 258A and BR2580A adapters plug into a 25-pair female cable connector. These adapters divide the 25-pair cable into six 4-pair (modular jack) circuits. See [Figure 23: 258A and BR2580A Adapters](#) on page 50.

The 356A adapter plugs into a 25-pair female cable connector. See [Figure 24: 356A Adapter](#) on page 51. The 356A adapter divides the 25-pair cable into eight 3-pair circuits. Although the circuits are 3-pair, the adapters modular jacks will accept the 8-wide modular plug used on the 4-pair station cable.



CAUTION:

Adapters wired similarly to the 356A should not be used. Their jacks do not accept 4-pair plugs.

Station circuit distribution from equipment room

This section explains the station circuit distribution from the equipment room to the information outlets for new wiring installations. Example connection diagrams are provided to show the options for running and connecting the station cables.

If most of the telephones/voice terminals that require remote powering are within 250 feet (76.2 meters) of the equipment room, 4-pair station circuits are run from the equipment room to the information outlets. If this is not the case, or if the customer requires 2-point administration, 3-pair station circuits are run from the equipment room to satellite locations. Then, the 4-pair station circuits are run from the satellite locations to the information outlets.

This section has information about

- [4-pair station circuits](#) on page 45
- [3-pair to 4-pair station circuit distribution](#) on page 45
- [Connected cable station adapters](#) on page 50

Lists of telephones and consoles currently sold are provided in [Table 7: Connectable telephone and consoles](#) on page 70.

4-pair station circuits

Four-pair circuits, via station cables, can be run directly from an equipment room MDF to a 258A or BR2580A adapter as shown in [Figure 18: 4-pair circuit distribution and connectivity](#) on page 46. The 4-pair station cables connect the adapter to the information outlets.

The 4-pair station cables can be run directly from the equipment room to the information outlets if 4-pair terminal blocks are used in the distribution field. See [Figure 19: 4-pair run to equipment room or satellite location](#) on page 47. The station cables must be field-terminated on the 110-type terminal blocks.

If 110-type terminal blocks are used with a modular plug-ended station cable, an adapter can be connected directly to the 110-type terminal block connectors. See [Figure 20: 4-pair run to equipment room or satellite location](#) on page 47.

3-pair to 4-pair station circuit distribution

[Figure 21: 3-pair to 4-pair satellite location connectivity](#) on page 48 shows the 3-pair circuit distribution from an equipment room MDF to a satellite location using 110-type hardware. Four-pair circuits are distributed from the satellite location to the information outlets.

Three-pair circuits can also be run directly from the equipment room MDF to a 356A adapter as shown in [Figure 22: 3-pair to 4-pair circuit distribution and connectivity](#) on page 49. Four-pair station cables connect the adapter to the information outlets. Four-pair station cables can be run directly from a satellite location to the information outlets as previously described.

Note:

Bridged taps are not allowed on any part of the station wiring.

Figure 18: 4-pair circuit distribution and connectivity

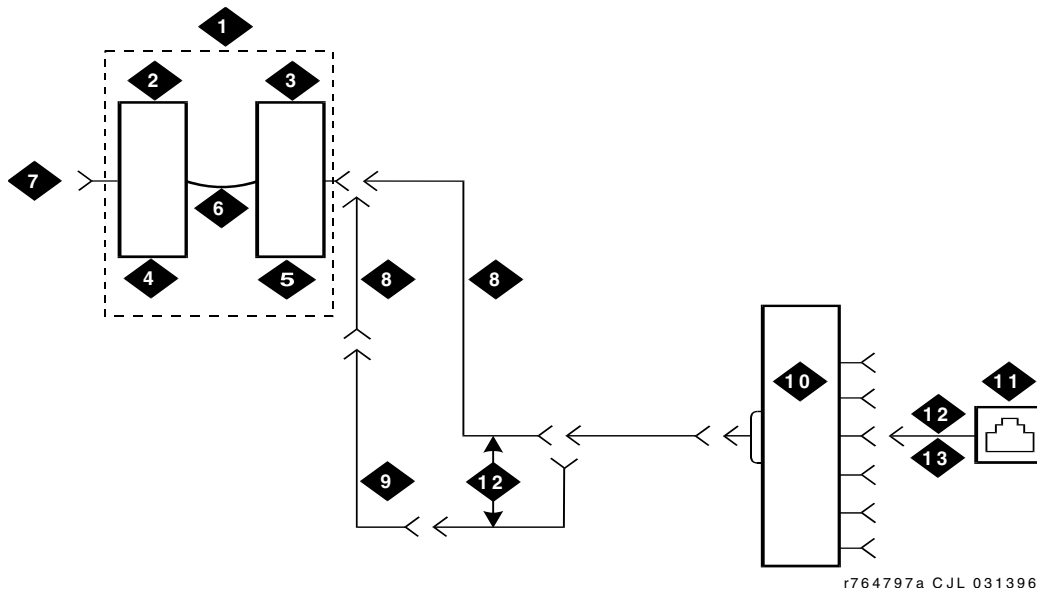

r764797a C.JL 031396

Figure notes:

- | | |
|--|--|
| 1. Part of Main Distribution Frame (MDF) | 7. To Media Gateway (3-Pair Modularity) |
| 2. 3-Pair Connecting Blocks | 8. B25A Cable |
| 3. 4-Pair Connecting Blocks | 9. Connectorized (Staggered Finger) Multiple 25-Pair Cable |
| 4. Purple Field | 10. 258A or BR2580A Adapter |
| 5. Blue Field | 11. Information Outlet |
| 6. Patch Cord or Cross-Connect Jumpers | 12. 4-Pair Circuit |
| | 13. DIW Station Cable (D-Inside Wire) |

Figure 19: 4-pair run to equipment room or satellite location

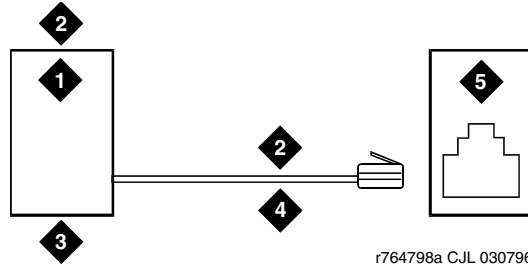

Figure notes:

- | | |
|--|---|
| <ul style="list-style-type: none"> 1. Station Side of MDF or Satellite Location 2. 4-Pair Circuit 3. Blue Field | <ul style="list-style-type: none"> 4. DIW Station Cable (D-Inside Wire) 5. Information Outlet |
|--|---|

Figure 20: 4-pair run to equipment room or satellite location

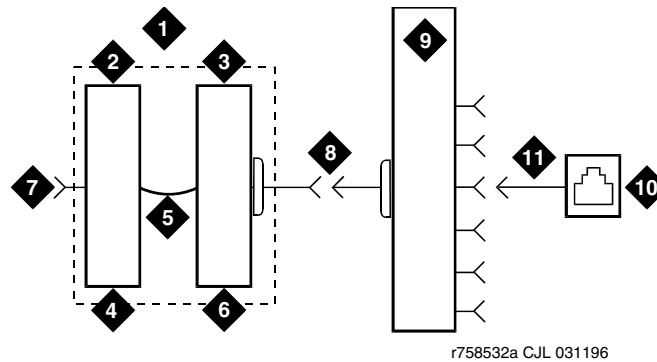
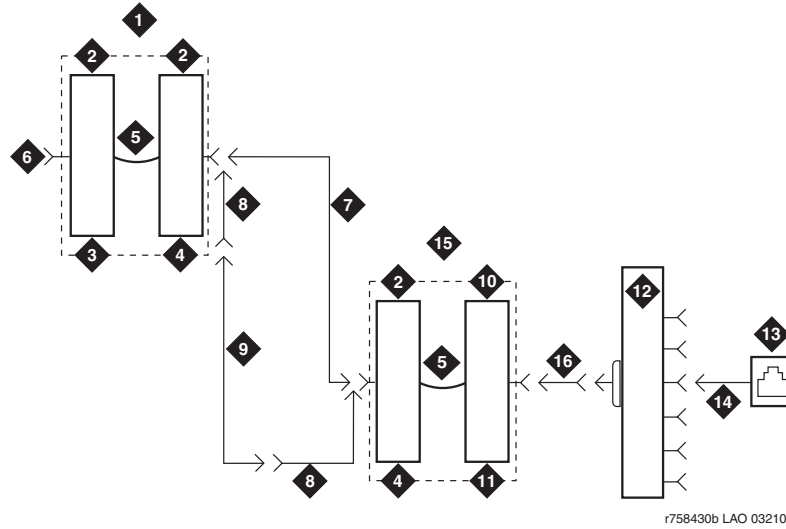

Figure notes:

- | | |
|--|--|
| <ul style="list-style-type: none"> 1. Part of MDF 2. 3-Pair Connecting Blocks 3. 4-Pair Connecting Blocks 4. Purple Field 5. Patch Cord or Cross-Connect Jumpers 6. Blue Field | <ul style="list-style-type: none"> 7. To Media Gateway (3-pair modularity) 8. A25D Cable 9. 258A or BR2580A Adapter 10. Information Outlet 11. 4-Pair Circuit (DIW station cable (D-Inside Wire)) |
|--|--|

Figure 21: 3-pair to 4-pair satellite location connectivity



r758430b LAO 032103

Figure notes:

- | | |
|---|--|
| 1. Part of MDF | 9. Connectorized (staggered finger) Multiple 25-Pair Cable |
| 2. 3-Pair Connecting Blocks | 10. 4-Pair Connecting Blocks |
| 3. Purple Field | 11. Blue Field |
| 4. White Field | 12. 258A or BR2580A Adapter |
| 5. Patch Cord or Cross-Connect Jumpers | 13. Information Outlet |
| 6. To Media Gateway (3-Pair Modularity) | 14. 4-Pair Circuit (DIW Station Cable [D-Inside Wire]) |
| 7. A25D Cable (3-Pair Circuits) | 15. Part of Satellite Location |
| 8. B25A Cable | 16. 4-Pair Circuits (B25A Cable) |

Figure 22: 3-pair to 4-pair circuit distribution and connectivity

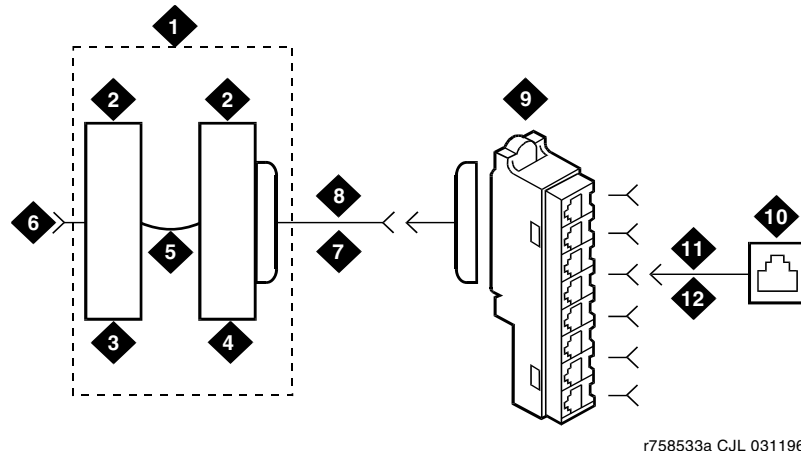

Figure notes:

- | | |
|--|---------------------------------------|
| 1. Part of Main Distribution Frame (MDF) | 7. B25A Cable |
| 2. 3-Pair Connecting Blocks | 8. 3-Pair Circuits |
| 3. Purple Field | 9. 356A Adapter |
| 4. Blue Field | 10. Information Outlet |
| 5. Patch Cord or Cross-Connect Jumpers | 11. 3-Pair Circuit in 4-Pair Wire |
| 6. To Media Gateway (3-Pair Modularity) | 12. DIW Station Cable (D-Inside Wire) |

Connected cable station adapters

Station adapters are used to provide modular connectivity either directly to a telephone or to an information outlet. See [Figure 23: 258A and BR2580A Adapters](#) and [Figure 24: 356A Adapter](#) on page 51.

Figure 23: 258A and BR2580A Adapters

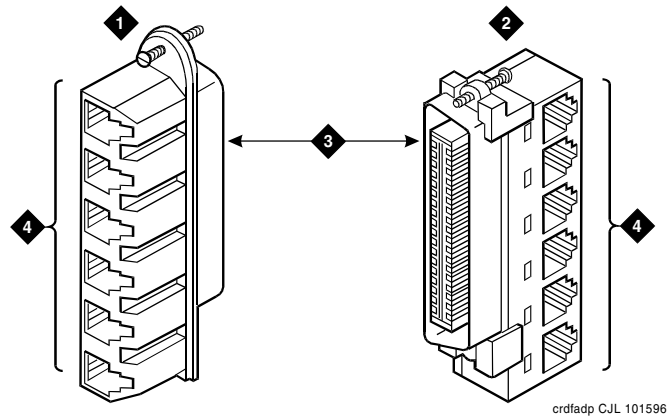
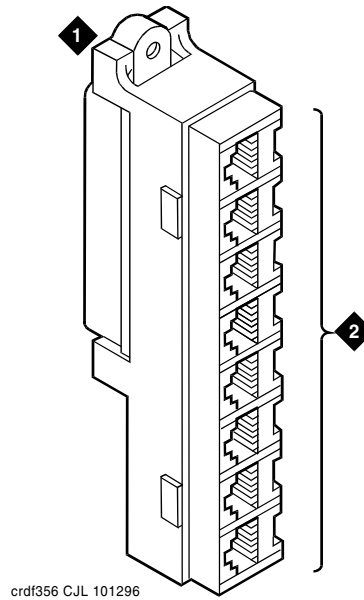

Figure notes:

- | | |
|--------------------|----------------------------------|
| 1. BR2580A Adapter | 3. 25-Pair Male Ribbon Connector |
| 2. 258A Adapter | 4. 4-Pair Modular Jacks (8 Pins) |

Figure 24: 356A Adapter



crdf356 C.JL 101296

Figure notes:

- 1. 356A Adapter
- 2. 4-Pair Modular Jacks (6 pins each, connected to 25-pair ribbon connector)

Table 4: Adapter ordering information

Description	Comcode
258A Adapter	102605136
BR2580A Adapter	403384720
356A Adapter	104158829
400B Adapter	103848859
400B2 Adapter	104152558
ZD8AJ Adapter	103881421
451 Adapter - Gray	103942272
451 Adapt. - White	103786240

Completing a provisioning plan

A provisioning plan should be completed before an installation. The plan determines an appropriate available port circuit on the media gateway for each telephone, trunk, and peripheral connection needed, and any auxiliary power for Basic Rate Interface (BRI) and certain display sets.

Obtain copies of the Port Assignment Record forms (or equivalent) from the customer or marketing representative. See [Figure 25: Port Assignment Record Form](#) on page 53 for an example of the form. These forms contain the port assignments and identify the extension numbers (**terminal number**) of the telephones. Enter the jack assignments at the equipment room.

The Port Assignment Record should have the following information:

- Station or trunk type or feature/service
- Building location (floor/room/desk/outlet)
- Extension number or trunk group and member number
- Port circuit location on the media gateway for each endpoint (media gateway/slot/circuit)
- Route from equipment room through site/satellite closets to each endpoint
- Auxiliary power supply, if required (main distribution frame (MDF), site/satellite closet, or information outlet)

Figure 25: Port Assignment Record Form

PORT ASSIGNMENT RECORD

CARRIER _____ Page _____

Slot	Port	Extension Number		Bldg Flr Rm	Voice Terminal Type	Voice Terminal Adjunct	Module	Power*	User Name/Use
		Old	New						
	01								
	02								
	03								
	04								
	05								
	06								
	07								
	08								
	09								
	10								
	11								
	12								
	13								
	14								
	15								
	16								
	17								
	18								
	19								
	20								
	21								
	22								
	23								
	24								

* To be completed by installation technician

r764787 PDH 07 1536

Installing sneak current and off premise protection

Protection from hazardous voltages and currents is required for all off-premises (out of building) trunks, lines, and terminal installations. Protection for incoming analog trunks is required between the incoming RJ21X or RJ2GX network interface and the media gateway for both trunk and off-premise circuit packs. Both over-voltage protection (lightning, power induction, and so forth), and sneak current protection are required.

Note:

Sneak current protectors with a rating of 350 mA at 600 volts must be Underwriter's Laboratory, Inc. (**UL**) listed for United States installation and Canadian Standards Association (**CSA**) certified for Canadian installation.

The following devices protect the media gateway from over-voltages:

- Analog trunks use the 507B sneak protector or equivalent. Over-voltage protection is normally provided by the local telephone company.
- DS1/E1/T1 circuits require isolation from exposed facilities. This isolation may be provided by a CSU (T1), LIU (E1), or other equipment that provides equivalent protection
- Analog telephones use 146 Series Line Protectors combined over-voltage and sneak current protection, or equivalent: See PEC 8310-0xx; SAP Code 10512x.
- DCP and ISDN-BRI terminals, and E&M tie trunks, use a low voltage version of the 146 Series Line Protectors.

The Model 507B sneak current fuse panel, or equivalent, is recommended for sneak current protection for analog trunks. The panel contains two 25-pair connectors, one fuse removal tool, and 50, 220029 sneak fuses (and two spares). Each column of sneak fuse panels requires approximately 8 inches (20 centimeters) of horizontal wall space.

See [Figure 26: Model 507B sneak fuse panel](#) on page 55. See [Table 5: Sneak fuse panel ordering information](#) on page 55 for ordering information.

Figure 26: Model 507B sneak fuse panel

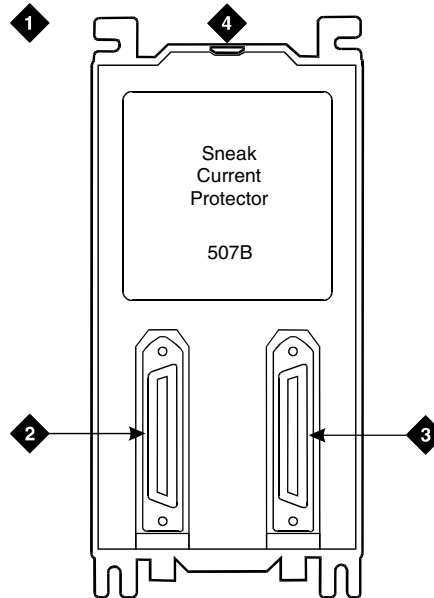

Figure notes:

- | | |
|--|--|
| <p>1. 507B sneak current protector</p> <p>2. 25-pair male connector (in)</p> | <p>3. 25-pair female connector (out)</p> <p>4. 220029 fuses (inside panel). Use a small screwdriver to pry top cover off</p> |
|--|--|

Table 5: Sneak fuse panel ordering information

Description	Comcode
157B Connecting Block	403613003
SCP-110 Protector	406948976
507B Sneak Current Fuse Panel	107435091
220029 Sneak Current Fuse	407216316
25-pair male connector	846300994
25-pair female connector	846300994

Connector cables (B25A male to female) connect the network interface to the sneak fuse panel. Also, 157B connecting blocks equipped with SCP-110 protectors can be used for sneak current protection.

MDF connections to stations and the public switched telephone network

The 507B includes 52 sneak fuses and two cables and can be ordered using PEC code 63210. Use the SCP-110 protectors with 110-type hardware and on the 507B sneak fuse panel. The SCP-110 Protectors can be ordered separately and installed on the 157B connecting block. Fifty protectors are required per block.

Install the 507B near the network interface or patch panels with locally obtained #12 x 3/4-inch screws (or equivalent).

[Table 6: Sneak fuse connector pinout](#) on page 56 is a pinout of the cable wiring and associated fuse numbers.

Table 6: Sneak fuse connector pinout

Connector pin numbers	Pair/fuse number
26/1	1
27/2	2
28/3	3
29/4	4
30/5	5
31/6	6
32/7	7
33/8	8
34/9	9
35/10	10
36/11	11
37/12	12
38/13	13
39/14	14
40/15	15
41/16	16
42/17	17
43/18	18
44/19	19
1 of 2	

Table 6: Sneak fuse connector pinout (continued)

Connector pin numbers	Pair/fuse number
45/20	20
46/21	21
47/22	22
48/23	23
49/34	24
50/25	25
2 of 2	

Installing sneak fuse panels

For general information, see [Installing sneak current and off premise protection](#) on page 54.

[Figure 26: Model 507B sneak fuse panel](#) on page 55, or equivalent, is recommended for sneak current protection. The panel contains two 25-pair connectors, fuse removal tool, and fifty 220029 sneak fuses (and two spares). See [Table 6: Sneak fuse connector pinout](#) on page 56 for pinout data.

To install sneak fuse panels:

1. Locate the 507B near the network interface or the main distribution frame (MDF).
2. Hold the panel against the mounting surface and mark the mounting screw locations. Drill pilot holes at the marked locations and partially install a locally obtained #12 x 3/4-inch screw into the two bottom mounting slots.
3. Slide the sneak fuse panel onto the mounting screws and tighten the screws securely.
4. Install a locally obtained #12 x 3/4-inch screw into the top two mounting slots and tighten securely.
5. Repeat the procedure for each sneak fuse panel.
6. Secure the B25A cable to the panel with the captive screw on the connector and a supplied cable tie.

Installing the coupled bonding conductor

The coupled bonding conductor (CBC) provides a path to ground for transient energy (for instance, lightning) by virtue of mutual inductance between itself and exposed telcom cables. The CBC connects on one end to an approved single-point ground, runs adjacent to the telcom cable, and connects on the other end to the CBC terminal bar at the main distribution frame (MDF).

The CBC can be:

- a 10 AWG (#25) (6 mm²) wire tie wrapped to the exposed telecom cables
- a metal cable shield around the exposed cables, or
- six spare pairs from the exposed cable

A minimum of 12" spacing should be maintained between the CBC and other power, ground, or non-exposed communications cables.

Installing coupled bonding conductor wires

To install coupled bonding conductor wires:

1. At the DC power cabinet, connect a 10 AWG (#25) (6 mm²) ground wire to the Ground Discharge Bar. See [Figure 27: Typical power and ground for a DC power cabinet](#) on page 59.
2. Route the 10 AWG (#25) (6 mm²) ground wire to the CBC ground terminal bar at the MDF.
3. Tie wrap the ground wire to the inside wiring cable.

Figure 27: Typical power and ground for a DC power cabinet

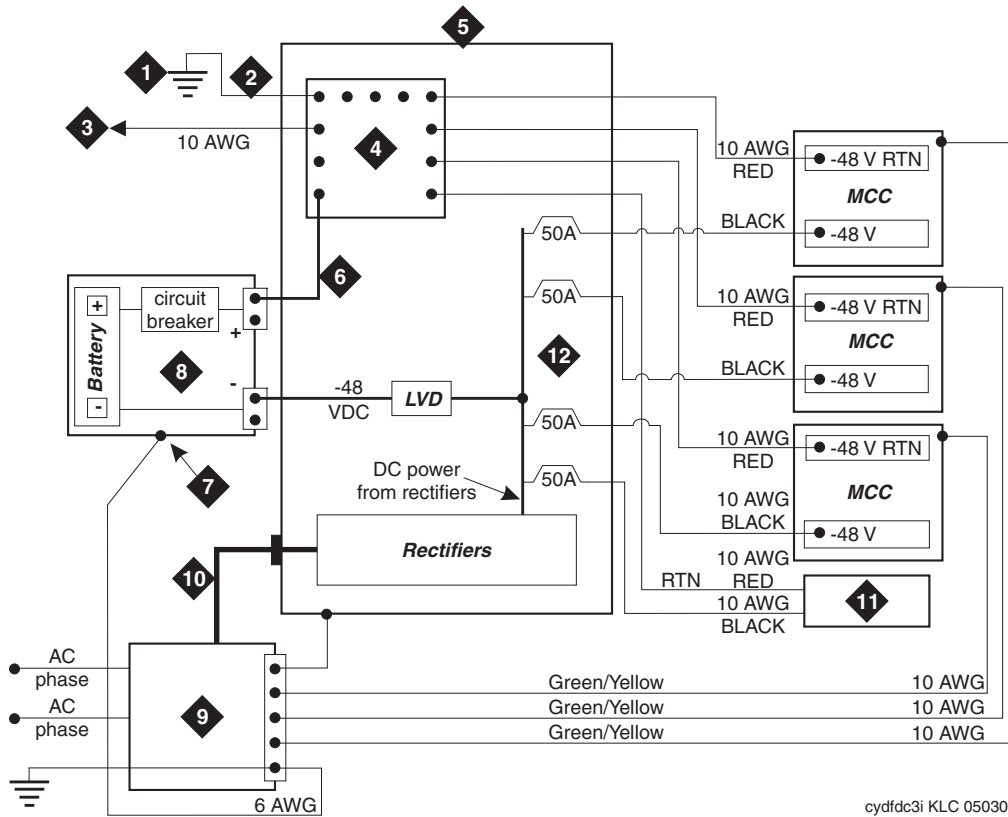

Figure notes:

- | | |
|--|--|
| <ol style="list-style-type: none"> 1. Approved Ground 2. 1 AWG Ground Wire 3. CBC Ground Terminal Bar at the MDF (if used) 4. System Single-point Ground Discharge Bar 5. DC Power Cabinet J58890R or new DC system | <ol style="list-style-type: none"> 6. Ground Wire for Battery (+) 7. Battery Frame Ground 8. DC Battery Cabinet 9. Main AC Supply (AC Mains) 10. AC to DC power cabinet 11. To Next DC-powered Media Gateway 12. DC load circuit breakers |
|--|--|

Note:

For a high-rise building, connect the CBC to an approved building ground on each floor.

Note:

Below is general information for installing the CBC in all installations having exposed facilities.

MDF connections to stations and the public switched telephone network

To provide the coupled bonding protection:

1. Cut a 10 AWG (#25) (2.5 mm²) wire long enough to reach from the equipment room single-point ground block (or DC power Ground Discharge Bar) to the MDF CBC block. See [Figure 28: Coupled Bonding Conductor](#) on page 61.
2. Connect one end of the 10 AWG (#25) (2.5 mm²) wire to the single-point ground block (or Ground Discharge Bar).
3. Route the wire next to the 25-pair cables connecting to the trunk/auxiliary (purple) field.
4. Tie wrap the 10 AWG (#25) (2.5 mm²) wire to the 25-pair cables.
5. Connect the 10 AWG (#25) (2.5 mm²) wire to the MDF CBC ground block.
6. Repeat the above steps for each CBC ground wire installed.

Figure 28: Coupled Bonding Conductor

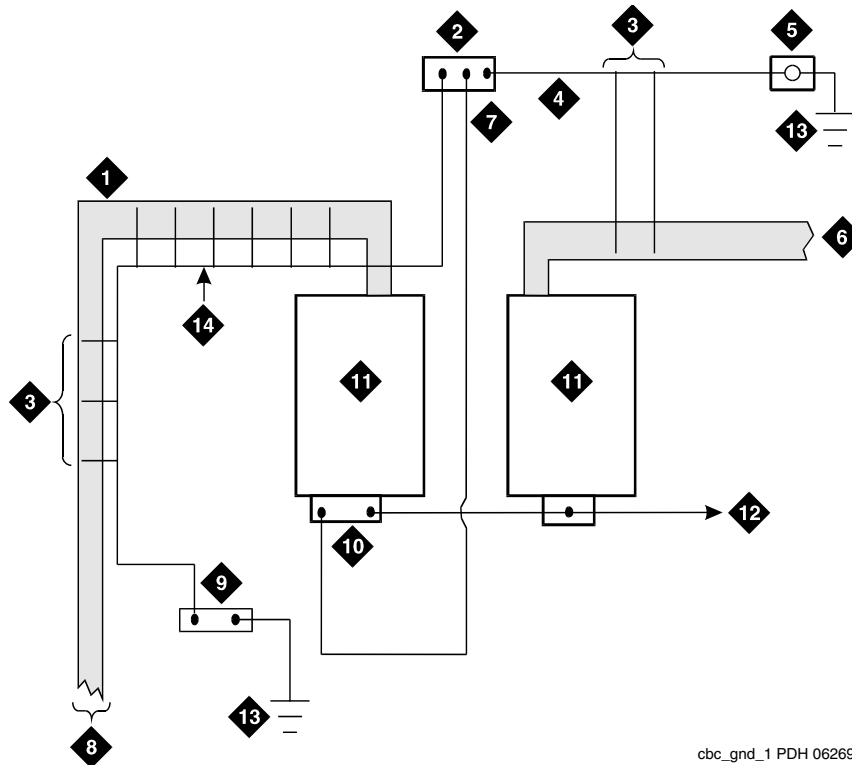

cbc_gnd_1 PDH 062696

Figure notes:

- | | |
|--|--|
| <ol style="list-style-type: none"> 1. 25-Pair Tip & Ring Cables to Media Gateways 2. Coupled Bonding Conductor (CBC) Terminal Block 3. Tie Wraps 4. Cable Shield or Six Spare Pairs 5. Ground on Carbon Block Protector or Equivalent 6. Trunk Cable to Network Interface 7. 10 AWG (#25) (2.5 mm²) Wire | <ol style="list-style-type: none"> 8. To Network Media Gateways 9. Battery Plant Ground Discharge Bar for Single-Point Ground 10. Cross-Connect Ground Block 11. Main Distribution Frame (MDF) 12. To Other Cross-Connect Ground Blocks 13. Approved Ground 14. Coupled Bonding Conductor (CBC) |
|--|--|

Installing and administering the patch cord/jumper

Before starting the patch cord installation, obtain a copy of the Port Assignment Record forms from the customer or marketing representative. See [Figure 25: Port Assignment Record Form](#) on page 53.

The white label identifying the terminal block row associated with circuits 17 to 24 connects to an identically labeled terminal block row at the satellite closet. See [Figure 29: Example 3-pair labeling to information outlet](#) on page 63. This is always the case for either 1-point or 2-point administration.

The satellite symbol must be installed at all connection points between the blue field and the information outlet. It must also be installed at the information outlet itself.

[Figure 30: Example 4-pair labeling to information outlet](#) on page 64 shows an example labeling scheme for 4-pair circuits from the equipment room to the information outlets. The labeling scheme for 3-pair circuits from the MDF to a satellite location.

Figure 29: Example 3-pair labeling to information outlet

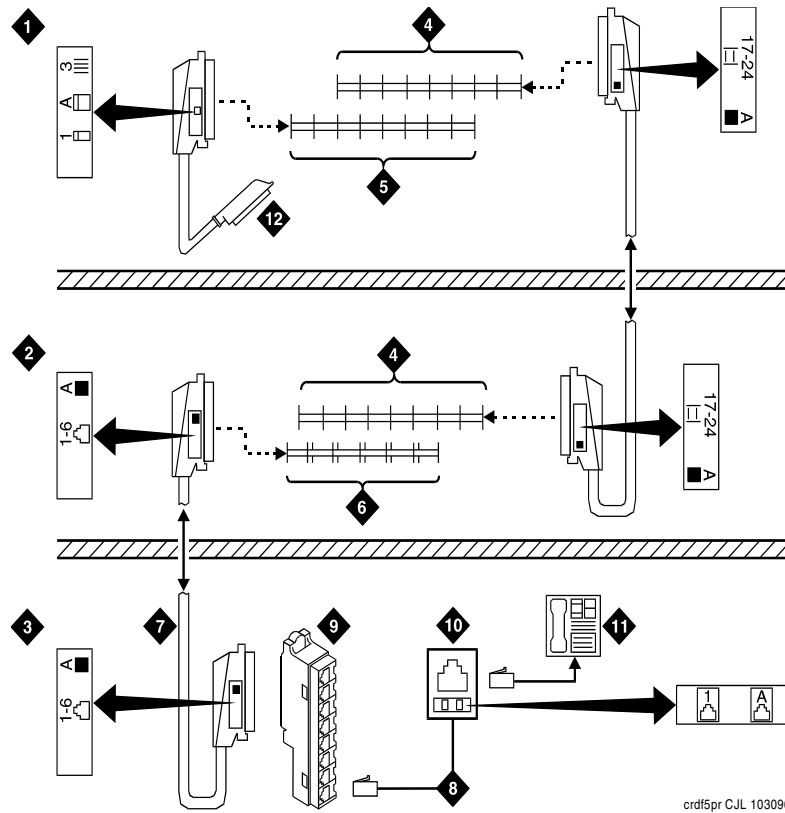

crdf5pr C.J.L. 103096

Figure notes:

- | | |
|---|---|
| 1. Equipment Room | 8. D-Inside Wire Cut Down to Connecting Block |
| 2. Satellite Location | 9. 258A Adapter |
| 3. Work Location | 10. Information Outlet |
| 4. White Row on 110 Terminal Block | 11. Telephone |
| 5. Purple Row on 110 Terminal Block | |
| 6. Blue Row on 110 Terminal Block | |
| 7. Central Location for Terminals 1 through 6 | |

Figure 30: Example 4-pair labeling to information outlet

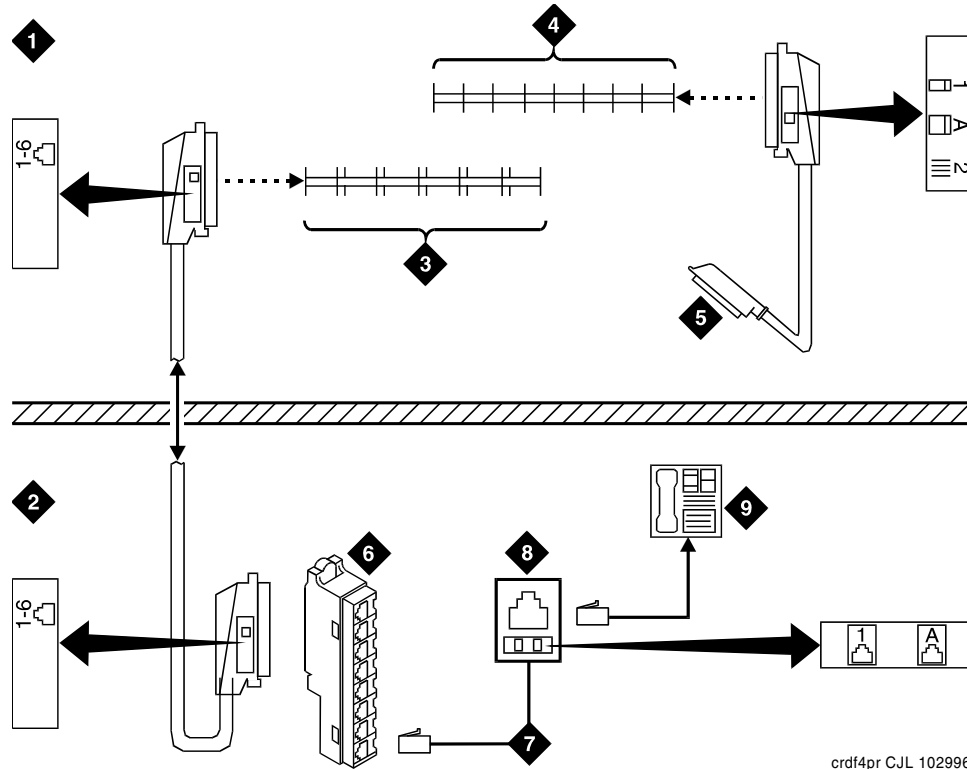

Figure notes:

- | | |
|--|---|
| 1. Equipment Room | 6. 258A Adapter |
| 2. To Central Location for Terminals 1 through 6 | 7. D-Inside Wire Cut Down to Connecting Block |
| 3. Blue Row on 110 Terminal Block | 8. Information Outlet |
| 4. Purple Row on 110 Terminal Block | 9. Telephone |
| 5. To Port Connector on Media Gateway (Media Gateway 1, Position B, Slot 03) | |

Labeling expansion control carrier cable (MCC1 Media Gateway only)

To label the expansion control carrier cable:

1. Place the appropriate **AUX** connector label on the assigned 110-type terminal block row.
2. On the expansion control carrier cable, place a yellow auxiliary label on the connectors at each end of the cable.
3. Write "AUX" on each label.

Connecting expansion control carrier outputs cable (MCC1 Media Gateway only)

To connect the expansion control carrier outputs cable:

1. Plug the connector cable in the **AUX** connector on the rear of the expansion control carrier.
2. Route the connector cable through the cable slack manager to the assigned 110-type terminal block in the yellow field of the trunk/auxiliary field.

Connecting trunk pairs using concentrator cables

[Figure 31: Connect trunk pairs using concentrator cables](#) on page 66 shows trunk pairs connected to the media gateway with concentrator cables. To install the cables:

1. Connect B25A cables between the network interface and sneak fuse panels.
2. Connect A25D cables from the sneak fuse panels to the 110-type terminal block connectors in the green field.
3. Connect patch cords/jumper wires from the terminal block in the green field to the associated terminal block in the purple field.
4. Connect the single-fingered end of the concentrator cables to the 110-type terminal block connectors in the purple field in Step 3.
5. Connect the other end (2/3-fingered end) of the concentrator cables to the appropriate carrier slots. Equipped carrier slots are identified on the CSD. Mark the nomenclature strips above the carriers to identify the slots.
6. Label connectors on each end of the cables that connect to the media gateway.
7. Route the cables down the sides of the media gateway and store the excess cable slack in the cable slack manager as previously described.

Figure 31: Connect trunk pairs using concentrator cables

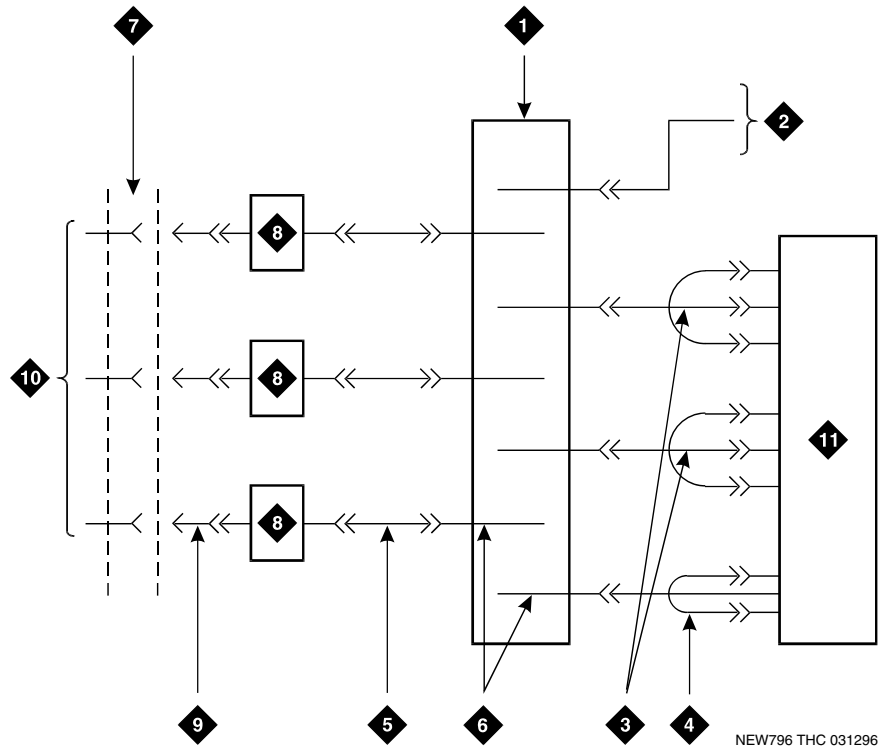

Figure notes:

- | | |
|--|---|
| 1. Trunk/Auxiliary Field | 6. Alternate Block/Rows |
| 2. To Expansion Control Carrier AUX Connector (MCC1 Media Gateway only) | 7. RJ21X/RJ2GX Network Interface |
| 3. Concentrator Cable (WP90929, List 1) | 8. Sneak Fuse Panel |
| 4. Concentrator Cable (WP90929, List 3) | 9. B25A Cable |
| 5. A25D (Male-to-Male) Cable | 10. Central Office Trunks |
| | 11. Media Gateway |

Connecting trunk pairs to media gateway using jumper wires to establish 3-pair modularity

[Figure 32: 3-pair modularity for trunk pairs for 1-pair trunks](#) on page 67 and [Figure 33: 3-pair modularity for trunk pairs for 3-pair Tie trunks](#) on page 68 show trunk pairs connected to the media gateway with jumper wires to establish 3-pair modularity.

To connect the trunk pairs to the purple field:

1. Connect B25A cables between the network interface and the sneak fuse panels. See [Figure 32: 3-pair modularity for trunk pairs for 1-pair trunks](#) on page 67.
2. Connect A25D/B25A cables from the sneak fuse panels to the 110-type terminal block-type connecting block connectors in the green field.
3. Connect 1-pair patch cords/jumper wires from each 110-type terminal block row in the green field to the 110-type terminal block rows in the purple field for 1-pair central office (CO) trunks or in [Figure 33: 3-pair modularity for trunk pairs for 3-pair Tie trunks](#) on page 68 for 3-pair tie trunks.

Figure 32: 3-pair modularity for trunk pairs for 1-pair trunks

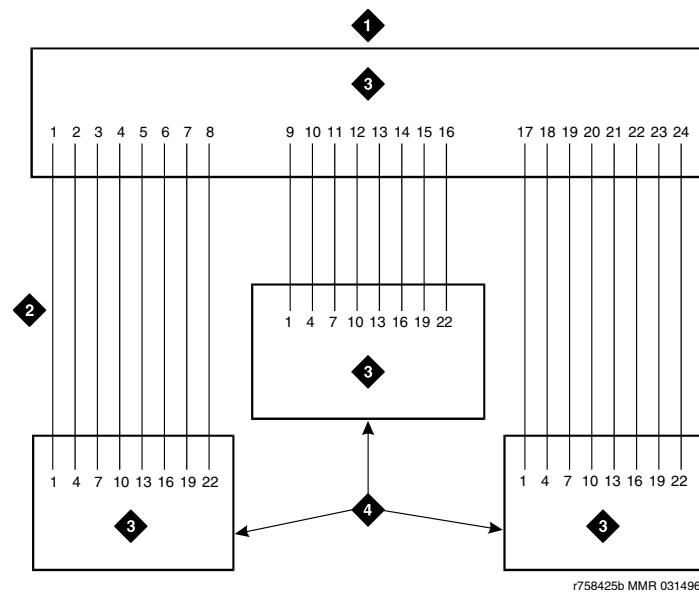

Figure notes:

- | | |
|-------------------|-----------------|
| 1. Green Field | 3. Pairs |
| 2. 1-Pair Jumpers | 4. Purple Field |

Figure 33: 3-pair modularity for trunk pairs for 3-pair Tie trunks

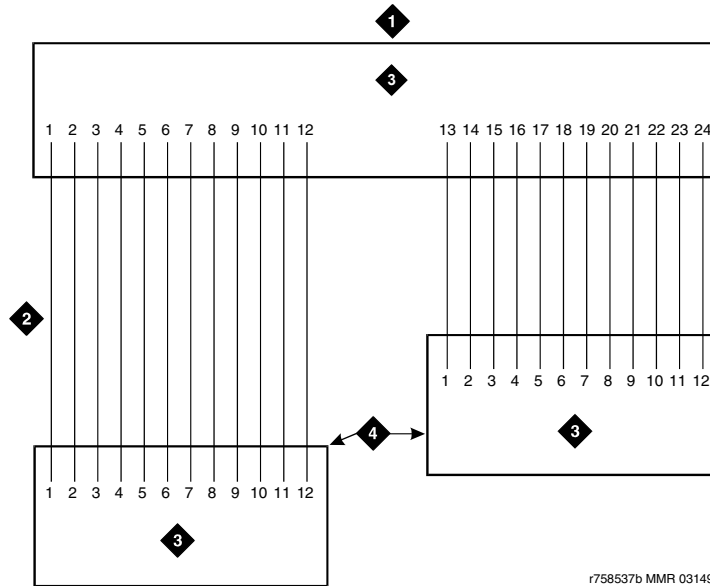

Figure notes:

- 1. Green Field
- 2. 1-Pair Jumpers
- 3. Pairs
- 4. Purple Field

Chapter 6: Installing and wiring telephones and trunks

The wiring procedures are the same for most Avaya telephones and other equipment.

This task list provides wiring examples of similar installation procedures. These are examples only; actual wiring procedures may vary at each site.

After installing the equipment, the data for the telephone features must be administered. These procedures are provided in the *Administrator Guide for the Avaya Communication Manager* (03-300509) or with the specific telephone or console.

Note:

See *Adding New Hardware for Avaya Servers and Gateways* (03-300684) to install the necessary peripheral equipment.



CAUTION:

Having a phone that is on an IP trunk too close to a fax machine can cause problems. If the phone is too close, the handset can pick up the tones from the fax machine and change itself into the fax mode.

To prevent this, turn down the volume on the fax machine, or move the phone set further away from the fax machine, or on the **IP Codec Set** screen (**change ip-codec-set**), set the **Fax** field to **off** if not sending or receiving faxes on the IP trunk.

Wiring telephones and trunks

This section includes the following wiring examples and wiring procedures:

- [Connecting telephones](#) on page 70
- [Analog tie trunk example](#) on page 76
- [Digital tie trunk example](#) on page 77
- [DS1 tie trunk example](#) on page 78
- [Auxiliary connector outputs \(MCC1 and SCC1 Media Gateways only\)](#) on page 81
- [Three-pair and four-pair modularity](#) on page 84
- [Adjunct power connection locations](#) on page 85
- [Attendant console example](#) on page 86

Installing and wiring telephones and trunks

- [Connecting external alarm indicators and auxiliary power](#) on page 88
- [Installing off-premises station wiring](#) on page 90
- [Off-premises or out-of-building stations](#) on page 91
- [Off-premises connections](#) on page 91
- [Emergency transfer units and associated telephones](#) on page 96
- [808A Emergency Transfer Panel and telephone installation examples](#) on page 97
- [Installing external ringing](#) on page 106
- [Installing the queue warning indicator](#) on page 107

See the Job Aid titled *Connector and Cable Diagrams (Pinout Charts)* (555-245-773) for information on pinouts.

Connecting telephones

This section includes the various analog, digital, and IP telephones can be connected to the media gateway including:

- [Connectable telephones and consoles](#) on page 70
- [Connecting a typical telephone](#) on page 73
- [Connecting adjunct power](#) on page 74
- [Connecting an analog station or 2-wire digital station](#) on page 75

Connectable telephones and consoles

[Table 7: Connectable telephone and consoles](#) on page 70 lists the telephones and consoles that can be connected to an Avaya media gateway.

Table 7: Connectable telephone and consoles

Telephone and console models	Type
16xx (Avaya one-X Deskphone Value Edition)	Internet Protocol (IP)
2500/2554	Analog
2402	Digital

1 of 3

Table 7: Connectable telephone and consoles (continued)

Telephone and console models	Type
2410	Digital
2420	IP/Digital
2520B Explosive Atmosphere	Analog
3127 Avaya Soundstation/SoundPoint Speakerphones: 3127-ATR, -STD, -EXP, -APE, -APX, -MIC, -PMI	Analog
3127 Avaya Soundstation/SoundPoint Speakerphones: 3127-DCP, -DCS, -DCE, -DPE, -DPX, -DDP, -DDX, -MIC, -PMI	Digital
3410	Wireless
3606, 3616, 3626	Wireless VoIP
3701, 3711	Internet Protocol (IP) DECT
46xx series: 4601, 4602, 4602SW, 4606, 4610SW, 4612, 4620, 4620SW, 4621SW, 4622SW, 4624, 4625SW, 4630, 4630SW, 4690	Internet Protocol (IP)
62xx series: 6211, 6219	Analog
64xx series: 6402/D, 6408D+, 6416D/D+M, 6424D+/D+M	Digital
9040 Avaya TransTalk	Wireless
96xx series (Avaya one-X Deskphone Edition IP telephones)	Internet Protocol (IP)
Avaya Agent Deskphone 16CC	
Enhanced Attendant Consoles: 302D	Digital
603F Avaya Callmaster IV	Digital
607A Avaya Callmaster V ACD Console	Digital
2 of 3	

Table 7: Connectable telephone and consoles (continued)

Telephone and console models	Type
606A Avaya CallMaster VI ACD Console	Digital
Softphones: Netmeeting H.323 IP Softphone CentreVu IP Agent Softconsole	Internet Protocol (IP)
3 of 3	

Connecting a typical telephone

The 302D Enhanced Attendant Console is used to describe a telephone connection typically used with the 84xx (4-wire) telephones.

The 302D does not require auxiliary power unless it has a 26C1 DXS console or Vacuum Fluorescent Display. The 302D attendant console always requires auxiliary (adjunct) power (-48 VDC). Power is connected to the console through Pins 7 and 8 of the information outlet. Only three consoles can be powered by the media gateway. When possible, the primary console should be powered from the media gateway so it has the same power failure backup as the media gateway.

The maximum cabling distance for the console powered from the media gateway is 350 feet (100 meters).

The general steps to connect a telephone are:

1. Choose a device to connect such as a 302D Attendant Console.
2. Choose the port circuit pack and its slot number, such as cabinet 1, slot 02.
3. Choose a port circuit on the port circuit pack, such as Port 05.
4. Install cross-connect jumpers to wire the terminal to the port circuit pack. See [Figure 34: 302D to 4-wire DCP wiring](#) on page 74. This pinout is for the TN754C DCP Digital Line 4-wire circuit pack.

 **CAUTION:**

Do not use the 329A power unit for the attendant console. Use an 1151B1, 1151B2, 1145A, or MSP-1 power unit.

5. For terminals needing adjunct power, wire -48 VDC and ground to appropriate pins on the terminal. See [Figure 34: 302D to 4-wire DCP wiring](#).

Figure 34: 302D to 4-wire DCP wiring

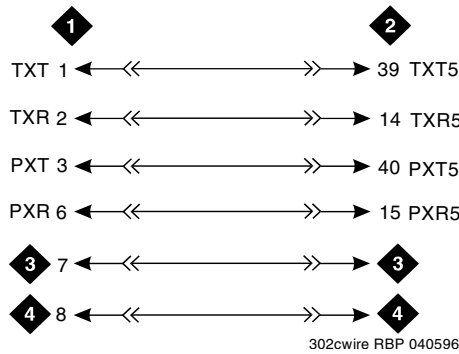

Figure notes:

- | | |
|--|--------------------------------------|
| 1. 302D Attendant Console | 3. -48 VDC From Adjunct Power |
| 2. 4-wire Digital Line Circuit Pack
(Position 1C02) | 4. Ground From Adjunct Power |

Connecting adjunct power

The 400B2 adapter is convenient for connecting local -48 VDC power to a modular plug. See [Figure 35: 400B2 Adapter connecting to a modular plug](#) on page 75.

Each port network can provide power for up to three attendant consoles. This source of power is preferred for the attendant consoles because it has the same battery backup as the media gateway. See [Auxiliary connector outputs \(MCC1 and SCC1 Media Gateways only\)](#) on page 81.

Note:

Adjunct power can be provided locally at the telephone or console by either the 1151B1 or 1151B2 power supply. Adjunct power can be provided from the equipment room or equipment closet with the 1145B power unit. See [Installing and wiring telephone power supplies](#) on page 109 for power supply information and installation procedures.

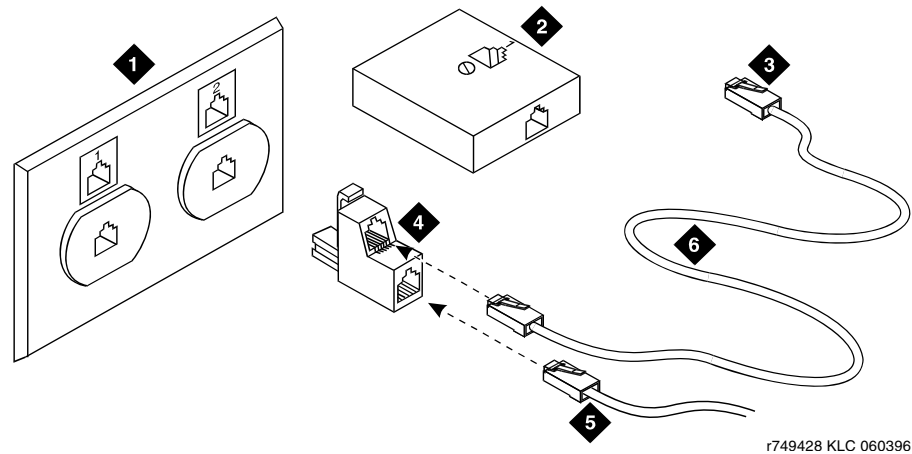
Figure 35: 400B2 Adapter connecting to a modular plug

r749428 KLC 060396

Figure notes:

- | | |
|---------------------------------------|---|
| 1. Flush-Mounted Information Outlet | 4. 400B2 Adapter |
| 2. Surface-Mounted Information Outlet | 5. To Telephone |
| 3. To Individual Power Unit | 6. Destination Service Access Point (DSAP) Power Cord |
-

Connecting an analog station or 2-wire digital station

This example is typical of the 2-wire digital stations (2420, 64xx, 302D), 2-wire analog stations (2500), analog central office (CO) trunks, direct inward dial (DID) trunks, and external alarms. See [Figure 36: 2500-type analog telephone wiring](#) on page 76.

To connect an analog station or 2-wire digital station:

1. Choose a peripheral to connect (such as a 2-wire digital station).
2. Choose the media module to use and its media gateway and slot number. For example: MM711 Analog Media Module, Media Gateway 002, Slot V2.
3. Choose a port circuit on the MM711 Media Module, for example port 03.
4. Install cross-connect jumpers to connect the pins from the 2-wire digital station to the appropriate pins on the MM711 Media Module. [Table 8: Station pinout chart](#) on page 76 shows a printout chart for two-wire stations.
5. Administer using *Administrator Guide for Avaya Communication Manager* (03-300509).

Figure 36: 2500-type analog telephone wiring

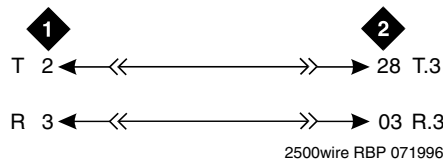

Figure notes:

1. 2500-Type Analog Station

2. MM711 Analog Media Module,
Position 1V301

Table 8: Station pinout chart

Jack Name	1	2	3	4	5	6	7	8
BRI-T			+TX	+RX	-RX	-TX	-V	GND
ADJUNCT	+Vadj	T0	-V	GNDVoice	RRVoice	+V	S0	TTVoice
DSS (QUEST)	DTX		DRX			OKdig	-V	+V
DSS (ISDN)								
BRI-A			GND	TX	RX	-V		
BRI-U				TX	RX		-V	GND
DCP				TIP	RING			
ANALOG				TIP	RING			
HANDSET			-TX	+RX	-RX	+TX		

Analog tie trunk example

This example shows how to connect analog tie trunk wiring from one IP Connect or Multi-Connect configuration to another one or any other Avaya configuration.

1. Set the option switches on the port circuit pack (such as TN760E Tie Trunk circuit pack).
2. See the job aid titled *Option Switch Settings (555-245-774)* for detailed information.
3. Install cross-connect jumpers to connect the pins from the tie trunk circuit pack to the appropriate leads on the external tie trunk.

4. [Figure 37: Analog Tie Trunk wiring](#) on page 77 shows a media gateway tie trunk connected to another media gateway tie trunk. Names of the tie trunk leads must be determined from the manufacturer or supplier of the external trunk circuit.
5. Administer on the **Trunk Group** screen on Avaya Site Administration (ASA). See the *Administrator Guide for Avaya Communication Manager* (03-300509) for more details.

Figure 37: Analog Tie Trunk wiring

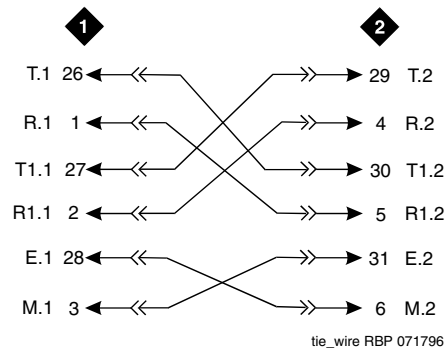

Figure notes:

- | | |
|------------------------------|---------------------------|
| 1. External Trunk or Adapter | 2. Tie Trunk Circuit Pack |
|------------------------------|---------------------------|
-

Digital tie trunk example

This example shows how to connect digital tie trunk wiring from one media gateway to another one or any other Avaya configuration. [Figure 38: Digital Tie Trunk wiring](#) on page 78 shows the connections.

1. Install cross-connect jumpers to connect the pins from the digital trunk circuit pack to appropriate pins on the manufacturer's or supplier's external digital trunk.
2. Set option switches on the port circuit pack (digital trunk).
3. See the job aid titled *Option Switch Settings* (555-245-774) for detailed information.
4. Administer on the DS1 and trunk group screens through ASA. See the *Administrator Guide for Avaya Communication Manager* (03-300509) for more details.

Figure 38: Digital Tie Trunk wiring

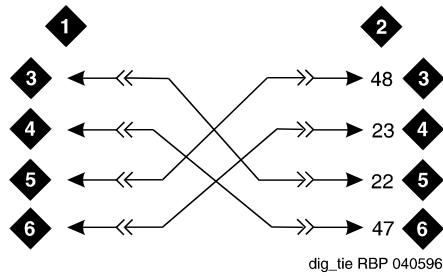

Figure notes:

- | | |
|-------------------------------|------------------------------|
| 1. External Trunk | 4. LO (Balanced Output Pair) |
| 2. Digital Trunk Circuit Pack | 5. LI |
| 3. LO | 6. LI (Balanced Input Pair) |

DS1 tie trunk example

Digital Signal Level 1 (DS1) tie trunks provide a 1.544 Mbps (T1) or 2.048 Mbps (E1) digital data service between two collocated configurations or between the configuration and a data network.

See these examples:

- [Collocated DS1 interface trunks](#) on page 78
- [DS1 interface trunks using T1 channel service unit](#) on page 79

For cable descriptions, see

- [DS1 cables](#) on page 80
- [Pinout of C6F cable](#) on page 80

Collocated DS1 interface trunks

Two TN464HP DS1 Interface circuit packs can be in collocated configurations. A DS1 Interface circuit pack in one configuration can be connected to a DS1 in another configuration. A C6D cable can be used if the distance is less than 50 feet (15.2 meters). If the distance is between 50 feet (15 meters) and 1,310 feet (399 meters), use a C6E cable.

Note:

The maximum distance between cabinets is 1,310 feet (399 meters).

DS1 interface trunks using T1 channel service unit

The T1 channel service unit (CSU) interfaces the DS1 interface trunks with the 1.544 megabits per second digital facility.

Connect the DS1 interface trunk to a T1 CSU. See [Figure 39: Typical connections to channel service unit](#) on page 79.

Note:

A 3150 CSU is shown, a 120A Integrated CSU (ICSU) may be used.

Contact your Avaya representative for maximum cabling distances for the 3127 series CSU or the 120A ICSU.

Figure 39: Typical connections to channel service unit

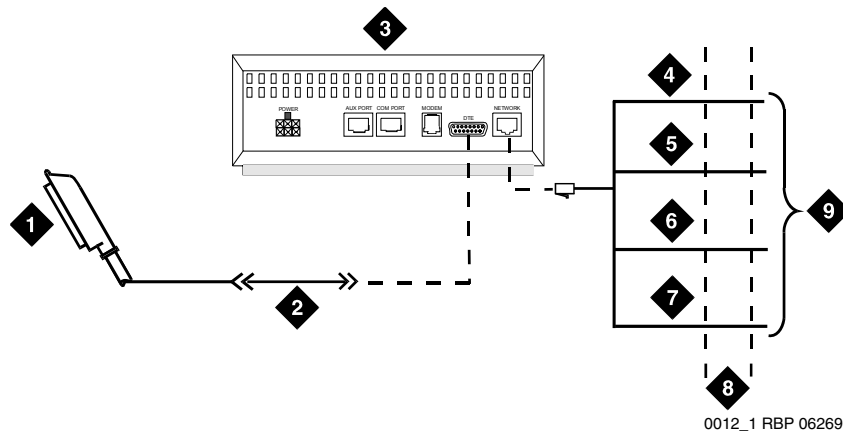

Figure notes:

- | | |
|--|---|
| 1. Connector to DS1 Interface Circuit Pack | 5. R (Ring) |
| 2. C6C Cable (For Distances Over 50 ft (15 m), Use C6E Cable(s)) | 6. T1 (Tip 1) |
| 3. T1 Channel Service Unit (CSU) 3150 Shown | 7. R1 (Ring 1) |
| 4. T (Tip) | 8. 1.544 Mbps Digital Service Interface |
| | 9. To T1 Carrier |

Table 9: DS1 cables

Connector cable	Description and usage
C6C connector cable	50-feet (15 meters) shielded cable equipped with a 50-pin male connector on one end and a 15-pin male connector on the other end. Use this cable to connect a DS1 tie trunk circuit pack to a CSU.
C6D connector cable	50-feet (15 meters) shielded cable equipped with a 50-pin male connector on each end. Use this cable to connect a DS1 tie trunks in collocated cabinets.
C6E connector cable	100-feet (31 meters) shielded cable equipped with a 50-pin male connector on one end and a 50-pin female connector on the other end. Use this cable as an “extension” cable between the DS1 tie trunk circuit pack and other connector cables.
C6F connector cable	50-feet (15 meters) shielded cable equipped with a 50-pin male connector on one end and a 3 inch (8 centimeter) stub on the other end. Use this cable to connect the DS1 tie trunk circuit pack to channel multiplexers requiring hardwired connections.

Table 10: Pinout of C6F cable

Wire color	Lead designation	Pin number
White/Green	L1* (High Side)	47
Green	L1	22
White/Brown	LO	48
Brown	LO* (High Side)	23
White/Slate	LBACK2	49
Slate	LBACK1	24

Auxiliary connector outputs (MCC1 and SCC1 Media Gateways only)

Connect a 25-pair cable from the **AUX** connector on the back of the expansion control carrier to a connecting block on the trunk/auxiliary field.

[Table 11: Auxiliary lead appearances at AUX connector](#) on page 81 shows the:

- control carrier outputs cable pinouts
- pinouts for an external alarm
- port circuit pack and telephone pin designations

The control carrier **AUX** connector outputs include:

- Two inputs for external alarm signals
- Seven -48 VDC power sources for emergency transfer units
- Three -48 VDC power sources for remotely powering three attendant consoles or telephone adjuncts
- A relay contact that actuates a customer-supplied light, bell, or similar device. The relay can activate when a major, minor, or warning condition occurs. The device connected to the alarm leads must not exceed a rating of 30Vac RMS or 60Vdc max, at 0.75A max. The customer provided alarm circuit must also meet the requirements for an SELV (Safety extra-low voltage) circuit; the alarm circuit power source must be a power supply or transformer meeting the UL 60950 SELV, Level 3, or Level 5 requirements.

Table 11: Auxiliary lead appearances at AUX connector

Color*	Pinouts	Output	Power
W-BL BL-W	26 1	Major [†]	
W-O O-W	27 2	Minor [†]	
W-G G-W	28 3	GRD	
W-BR BR-W	29 4	GRD	
W-S S-W	30 5	GRD	
R-BL BL-R	31 6	GRD	
			1 of 3

Table 11: Auxiliary lead appearances at AUX connector (continued)

Color*	Pinouts	Output	Power
R-O O-R	32 7	GRD	
R-G G-R	33 8	Not Connected	
R-BR BR-R	34 9	Not Connected	
R-S S-R	35 10	Not Connected	
BK-BL BL-BK	36 11	-48 GND	Emergency Transfer Relay Power
BK-O O-BK	37 12	-48 GND	
BK-G G-BK	38 13	-48 GND	
BK-BR BR-BK	39 14	-48 GND	
BK-S S-BK	40 15	-48 GND	
Y-BL BL-Y	41 16	-48 GND	
Y-O O-Y	42 17	-48 GND	
Y-G G-Y	43 18	Not Connected	
Y-BR BR-Y	44 19	GND -48	AUX Power
Y-S S-Y	45 20	GND -48	
V-BL BL-V	46 21	GND -48	
V-O O-V	47 22	Not Connected	
V-G G-V	48 23	Ext Alarm A ³ Ext Alarm Return	
			2 of 3

Table 11: Auxiliary lead appearances at AUX connector (continued)

Color*	Pinouts	Output	Power
V-BR BR-V	49 24	Not Connected	
V-S S-V	50 25	INADS Tip INADS Ring	
			3 of 3

*. Color designation is the main wire color and the color of the stripe on the wire. The following wire colors apply:

- W White
- BL Blue
- O Orange
- G Green
- BR Brown
- S Slate (Grey)
- R Red
- BK Black
- Y Yellow
- V Violet

†. External alarm with signal incoming to server.

‡ External alarm with signal outgoing from server.

[Table 12: Station pinout chart](#) provides the station printout chart.

Table 12: Station pinout chart

Jack Name	1	2	3	4	5	6	7	8
BRI-T			+TX	+RX	-RX	-TX	-V	GND
ADJUNCT	+Vadj	T0	-V	GNDVoice	RRVoice	+V	S0	TTVoice
DSS (QUEST)	DTX		DRX			OKdig	-V	+V
DSS (ISDN)								
BRI-A			GND	TX	RX	-V		
BRI-U				TX	RX		-V	GND
DCP				TIP	RING			
ANALOG				TIP	RING			
HANDSET			-TX	+RX	-RX	+TX		

Three-pair and four-pair modularity

[Figure 40: 3-pair and 4-pair modularity](#) on page 84 is from the port circuit pack to the voice or data terminal.

Most terminals connect to an information outlet (modular jack) installed at the work location. Make the connections from the port circuit pack to the modular jacks, as shown in [Figure 40: 3-pair and 4-pair modularity](#) on page 84. Then plug the terminal into the modular jack.

[Adjunct power connection locations](#) on page 85 shows three methods of connecting adjunct power.

Figure 40: 3-pair and 4-pair modularity

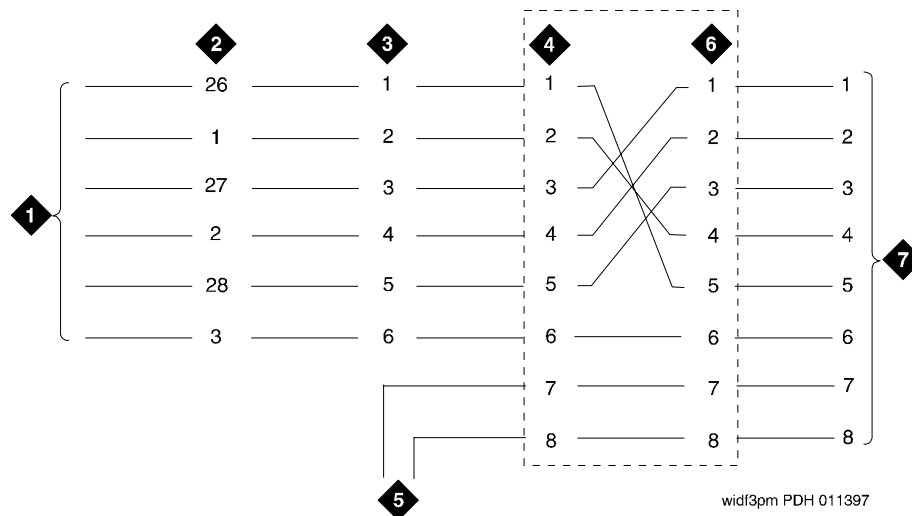

Figure notes:

- | | |
|--|---|
| <ul style="list-style-type: none"> 1. Port Circuit Pack 2. Media Gateway Connector Pins (3-Pair Modularity) 3. Main Distribution Frame (MDF) Pins (3-Pair Modularity) | <ul style="list-style-type: none"> 4. Input to Information Outlet (4-Pair Modularity) 5. Adjunct Power 6. Output From Information Outlet (4-Pair Modularity) 7. Voice or Data Terminal Pins |
|--|---|

Adjunct power connection locations

[Figure 41: Example adjunct power connections](#) on page 85 shows typical connection locations for adjunct power. Adjunct power for station equipment may be supplied from the equipment room, satellite location, or the work location.

For this figure, the following example is used:

1. If 25 telephones are connected to the media gateway and all 25 telephones need adjunct power, install a bulk power supply in the equipment room.
2. If only ten of the telephones need adjunct power, install a bulk power supply at the satellite location.
3. If only one telephone needs adjunct power, install the individual power supply at the work location.

Figure 41: Example adjunct power connections

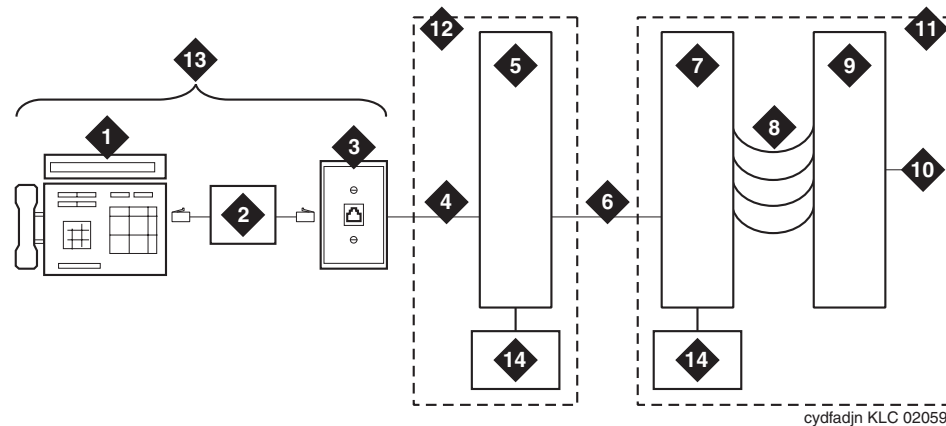

Figure notes:

- | | |
|---|---|
| 1. Typical Display Telephone | 8. 100P6A Patch Cord or Jumpers |
| 2. Individual Power Supply (Such as 1151B1 or 1151B2) | 9. Media Gateway Side of Main Distribution Frame (MDF) |
| 3. Information Outlet (Modular Jack) | 10. 25-Pair Cable to Media Gateway (Analog Line Circuit Pack) |
| 4. 4-Pair D-Inside Wire (DIW) Cable | 11. Equipment Room |
| 5. Satellite Site or Adapter Location | 12. Satellite Location |
| 6. 25-Pair D-Inside Wire (DIW) Cable | 13. Work Location |
| 7. Station Side of Main Distribution Frame (MDF) | 14. Bulk Power Supply (such as 1145B) |

Attendant console example

Perform these tasks to install an attendant console

- [Installing the attendant console](#) on page 87
- [Installing the 26B1 Selector Console](#) on page 88

Attendant console cabling distances, local and phantom power

A console's maximum distance from the media gateway is limited. The maximum distance for a 302D console is as shown in [Table 13: Attendant console cabling distances](#).

Table 13: Attendant console cabling distances

Enhanced Attendant Console (302D)	24 AWG wire (0.5106 mm ²)		26 AWG wire (0.4049 mm ²)	
	Feet	Meters	Feet	Meters
With Selector Console				
Phantom powered	800	244	500	152
Locally powered	5,000	1,524	3,400	1,037
Without Selector Console				
Phantom powered	1,400	427	900	274
Locally powered	5,000	1,524	3,400	1,037

Auxiliary power

 **CAUTION:**

Do not use the 329A power unit for the attendant console.

The nonessential functions of an attendant console and its optional 26A1 or 24A1 selector console derive their power from an auxiliary power source. Of the maximum of 27 attendant consoles, 3 of the consoles can derive auxiliary power from the media gateway and through the auxiliary cable located in the trunk/auxiliary field. Provide auxiliary power for a primary attendant console through this cable so the console remains fully operational during short power outages.

An attendant console can also derive auxiliary power from:

- Individual 1151B1 or 1151B2 power supply
- 258A-type adapters
- Bulk power supplies such as the 1145B2

A console's maximum distance from its auxiliary power source is:

- 800 feet (244 meters) for a 302A1
- 350 feet (107 meters) for a 301B1 and 302D

Hard-wire bridging

Analog type hard-wire bridging is not allowed for any **DCP** endpoints. Hard-wire bridging provides no way of combining the digital output of two bridged **DCP** sets. Also, a bridged endpoint causes degradation of the **DCP** signal.

 **CAUTION:**

Bridging or paralleling these endpoints can cause electrical damage to the consoles or cause the circuit pack to remove power from the consoles.

Dual wiring of 2-wire and 4-wire endpoints

Do not simultaneously wire a 2-wire and 4-wire endpoint to the same equipment location in an MDF. The Avaya configurations use separate circuit packs to interface 2- and 4-wire endpoints.

Installing the attendant console

To install the attendant console:

1. Install the attendant console and connect the modular cord to the information outlet.
2. Install labels per the attendant console form and the Display Module form assignments.
3. Install a digital line circuit pack in the assigned slot (if an additional circuit pack is required).
4. Administer the forms listed in "Attendant Console" in *Administrator Guide for Avaya Communication Manager* (03-300509).

Installing the 26B1 Selector Console

To install the 26B1 Selector Console:

1. Connect the supplied 3-foot (1 meter) D8AC cable to the modular jack on the bottom of the 26B1 Selector Console.
2. Route the cable to the attendant console and connect to the DXS/BLF jack.
3. Attach labels according to the Attendant Console form.
4. Administer the console using *Administrator Guide for Avaya Communication Manager* (03-300509).

Connecting external alarm indicators and auxiliary power

Alarms can be generated on adjunct equipment, sent to the server, and recorded and reported as “external alarms.” A typical major alarm *input* is from an uninterruptible power supply (UPS).

The media gateway provides a relay contact that can operate a customer-provided alarm, such as a light or bell. The circuitry and power source are customer-provided. The device connected to the alarm leads must not exceed a rating of 30Vac RMS or 60Vdc max, at 0.75A max. The customer provided alarm circuit must also meet the requirements for an SELV (Safety extra-low voltage) circuit; the alarm circuit power source must be a power supply or transformer meeting the UL 60950 SELV, Level 3, or Level 5 requirements. See [Figure 42: IPSI-2 cabling](#) and [Figure 43: Sample Issue 1 IPSI-2 alarm cable connectivity](#) on page 89.

Figure 42: IPSI-2 cabling

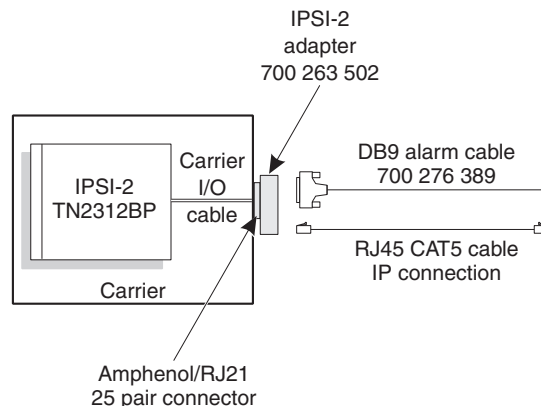
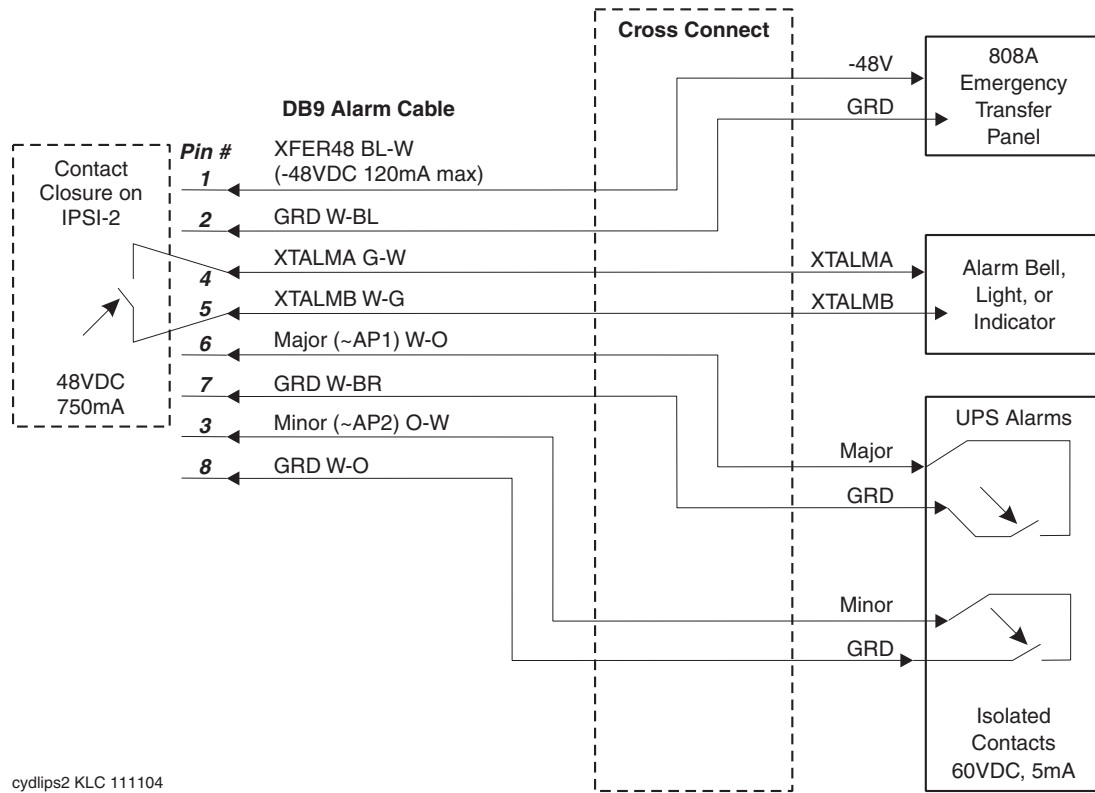

Figure 43: Sample Issue 1 IPSI-2 alarm cable connectivity



To connect the external alarm indicators and the auxiliary power:

1. Connect 1 major (Brown-White and White-Brown) and 1 minor (Orange-White and White-Orange) alarm *input* pair to the trunk/auxiliary field from the TN2312BP Adapter DB9 alarm connector. See [Table 14: Alarm Inputs at TN2312BP Adapter DB9 Alarm Connector](#) on page 90. Alarms can be generated on adjunct equipment, sent to the Avaya media gateway, and recorded and reported as “external alarms.” The adjunct equipment must provide an isolated contact closure across the alarm leads provided by the Avaya media gateway. The contact must be rated at a minimum of 60 VDC with a current carrying capacity of 5 mA minimum.
2. Connect an external alarm *output* (Green-White and White-Green).
3. Note which device connects to which alarm and give this information to your Avaya representative for troubleshooting purposes.

Installing and wiring telephones and trunks

4. Connect emergency transfer power (Blue-White and White-Blue) as shown in [Table 14: Alarm Inputs at TN2312BP Adapter DB9 Alarm Connector](#).

Table 14: Alarm Inputs at TN2312BP Adapter DB9 Alarm Connector

Color	AUX Connector	Pair Name *
White-Blue	Ground (Pin 2)	XR
Blue-White	XFER48 (Emergency Transfer) (Pin 1)	
White-Orange	Ground (Pin 8)	1m
Orange-White	AP2 Minor Alarm Input (Pin 3)	
White-Green	EXTALMB (Ground) Alarm Output (Pin 5)	AL
Green-White	EXTALMA Alarm Output (Pin 4)	
White-Brown	Ground (Pin 7)	1M
Brown-White	AP1 Major Alarm Input (Pin 6)	

*. For additional information on the auxiliary field on the Main Distribution Field, see [Figure 49: Connections for telephone used for emergency transfer](#) on page 103 and [Figure 50: Connections for telephone used for emergency transfer and as normal extension](#) on page 104.

Installing off-premises station wiring

The local telephone company provides cabling outside the building for off-premises stations. The off-premises stations can appear on any of the RJ21X network interfaces provided for the central office (CO) trunks.

 **CAUTION:**

Only an **FCC**-approved (or equivalent) analog type telephone (such as a 2500-type), can be used as an off-premises station. The TN746B and TN2183 Analog Line circuit packs can be connected to off-premises stations.

To install the off-premises station wiring:

1. Install an A25D (male to male) cable between the RJ21X network interface and a sneak fuse panel.
2. At the main distribution frame (MDF), connect jumper wires between one row/connecting block in the green field and up to three rows/connecting blocks in the purple field to concentrate the analog line pairs.

3. Connect an A25D cable between the sneak fuse panel and the terminal block connector associated with the green row in the previous step.
4. Install a green label on the terminal block to identify the remote location.
5. Administer per the *Administrator Guide for Avaya Communication Manager* (03-300509).

Off-premises or out-of-building stations

Out-of-building campus stations are telephones not physically located in the same building as the equipment room but located on the same property. Only analog telephones connected to TN746B, TN791, TN793, TN793B, TN793CP, TN2183, TN2215, TN2793, or TN2793B Analog Line circuit packs can be installed out-of-building.

Off-premises connections

[Figure 44: Connections for 1 to 8 out-of-building analog telephones](#) on page 92 shows the connections for 1 to 8 off-premises analog telephones.

[Figure 45: Connections to 24 out-of-building telephones](#) on page 93 shows the connections for up to 24 off-premises analog telephones. Concentrations of analog line pairs are used at both buildings to minimize the off-premises wiring required. At the MDF, jumpers must be connected between one row/connecting block in the white field and up to three rows/connecting blocks in the purple field. At the station location, a WP-90929, List 1 Concentrator Cable is used. There are eight station appearances on each of the three fingers of the concentrator cable.

The maximum distance from the media gateway to the out-of-building telephone is 6,000 feet (1,829 meters) using 24 AWG (#5) (0.5 square millimeters) wire.

The maximum range of out-of-building analog telephones (500-, 2500-, or 7100-types) connected to an analog line circuit pack should be such that the maximum loop resistance does not exceed 1,300 ohms.

Figure 44: Connections for 1 to 8 out-of-building analog telephones

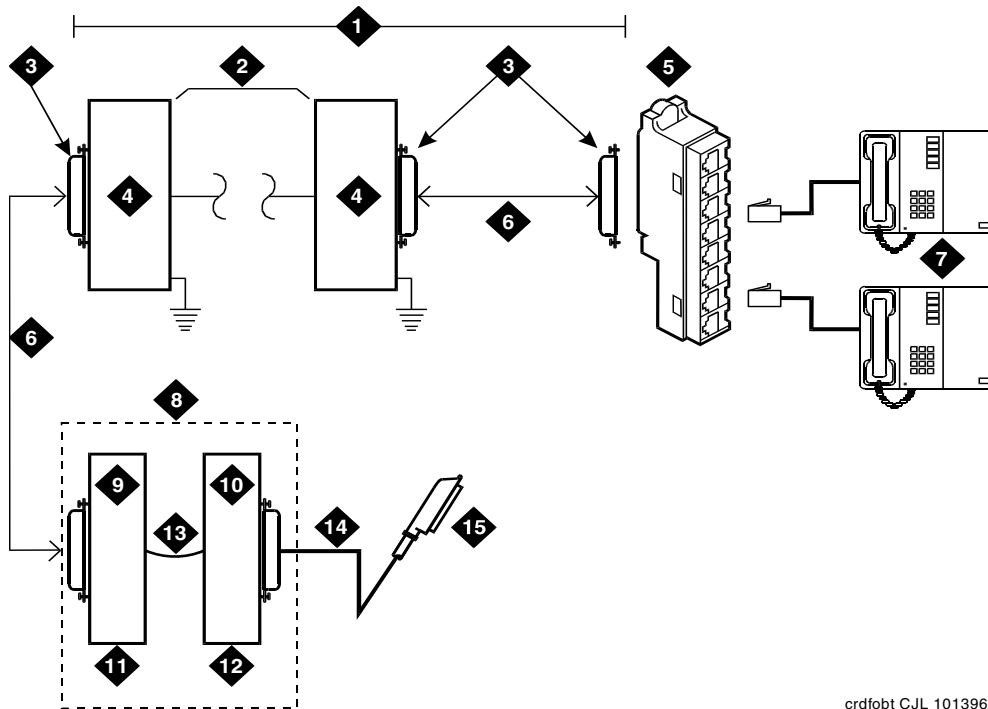

crdfobt C.J.L 101396

Figure notes:

- | | |
|--|--|
| <ol style="list-style-type: none"> 1. Locally Engineered Cables and Equipment 2. Out-of-Building Wiring 3. 25-Pair Connector 4. Multi-Pair Protector Units (Primary Protectors with Heat Coils or Equivalent with Sneak Current Protection) 5. 356A Adapter 6. B25A Cable (Male to Female) 7. Out-Of-Building Analog Telephones | <ol style="list-style-type: none"> 8. Part of Main Distribution Frame (MDF) 9. Station Side 10. Media Gateway Side 11. White Field 12. Purple Field 13. Cross-Connect Jumpers 14. Tip and Ring Wires 15. To Analog Line Circuit Pack |
|--|--|

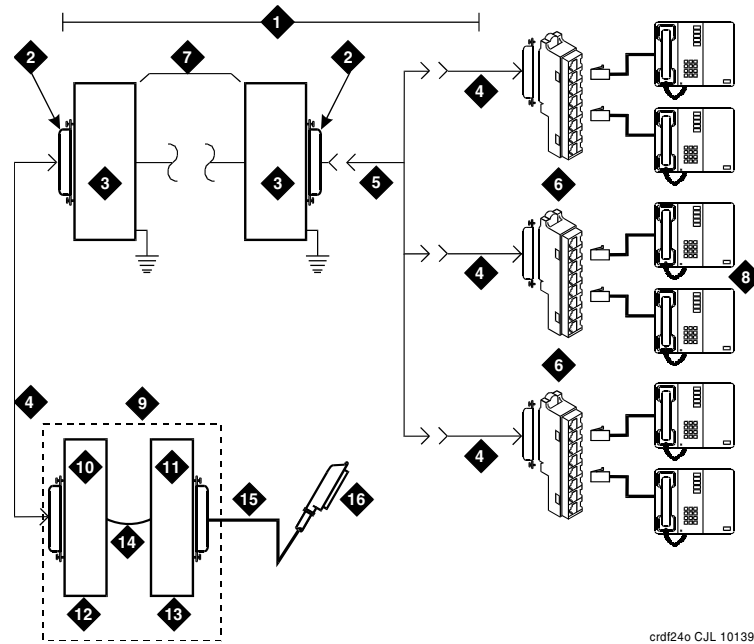
Figure 45: Connections to 24 out-of-building telephones**Figure notes:**

- | | |
|--|--|
| <ol style="list-style-type: none"> 1. Locally Engineered Cables and Equipment 2. 25-Pair Connector 3. Multi-Pair Protector Units (Primary Protectors with Heat Coils or Equivalent with Sneak Current Protection) 4. B25A Cable (Male to Female) 5. Concentrator Cable (WP90929 List 1) 6. 356A Adapter 7. Out-of-Building Wiring | <ol style="list-style-type: none"> 8. Out-Of-Building Analog Telephones 9. Part of Main Distribution Frame (MDF) 10. Station Side 11. Media Gateway Side 12. White Field 13. Purple Field 14. Cross-Connect Jumpers 15. Tip and Ring Wires |
|--|--|

Off-premises protection requirements

Both building entrances require carbon block or equivalent protection and sneak current protection. Protection can be provided by:

- a 4-type protector, which is equipped with a heat coil
- a 3-type protector plus a separate sneak current protector

Installing and wiring telephones and trunks

The 4-type protector is the preferred device. For installations not using primary protection, 4-type protectors should always be used. When the 3-type protector is already installed, a separate sneak current protector is required.

The multi-pair protector units and the off-premises cabling must be locally engineered. Connected multi-pair protector units (female 25-pair connector) are recommended.

[Table 15: Analog line circuit protectors](#) shows the recommended protectors.

Table 15: Analog line circuit protectors

Primary*	Primary (with heat coil)	Sneak current protectors*
3B1A (carbon)	4B1C (carbon)	220029 Fuse
3B1E-W (wide gap gas tube)	4B1E-W (wide gap gas tube)	SCP-1
3C1S (solid state)	4C1S (solid state)	

*. The 3-type protectors should be used only if they are already part of the existing protection system. A sneak current protector is always required when a 3-type primary protector is used.

For catalogs and ordering information, go to the Avaya Cable Management Systems for Service Providers Web site (<http://connectivity.avaya.com/exchangemax/>) and click **Products & Solutions**.

Telephone restrictions for exposed environments

Analog telephones connected to TN746B Analog Line circuit packs cannot be installed in an exposed environment.

Digital Out-of-Building Telephone Protection

Digital out-of-building telephones require protection at both building entrances. The 4C3S-75 Enhanced Protector and the ITW Linx Enhanced Protector can be used to protect digital telephones and digital line circuit packs. These units provide primary and sneak current protection. The 4C3S-75 is equipped with a heat coil for sneak current protection, and the ITW Linx is equipped with replaceable fuses for sneak current protection.

Note:

The TN2181 16-port, 2-wire digital line circuit pack may not be approved for some out-of-building uses. Contact your Avaya representative for more information.

The 4C3S-75 may be used only with TN754B Digital Line circuit packs. [Table 16: Digital Voice Circuit Protectors](#) lists the approved protectors.

Table 16: Digital Voice Circuit Protectors

Circuit Pack	Enhanced Primary Protector (With Sneak Current Protection)
TN754B all vintages	4C3S-75 or ITW Linx
TN2181 all vintages	4C3S-75 or ITW Linx
TN2224CP all vintages	4C3S-75 or ITW Linx

When possible, all new and reused wiring installations should use blocks that accept the standard 5-pin plug-in 4C3S-75 protector. However, there are reused wiring installations where this may not be cost effective. For these installations, the ITW Linx protector may be installed.

An example of this is where screw-type carbon block protectors—or other non-plug-compatible types—are in place and it is too costly to reterminate the outside plant cable on a 5-pin mounting block for only a few out-of-building terminals.

Installing the ITW Linx Enhanced Protector

The ITW Linx Enhanced Protector can be installed in series with existing primary protection. The ITW Linx Enhanced Protector mounts directly on connecting blocks and requires a separate ground bar.

Installing the 4C3S-75 Enhanced Protector

The 4C3S-75 protector cannot be installed in series with other types of primary protection. It must be installed as the only protection on the line entering the building. For the 4C3S-75 protector, there are a variety of 25-, 50-, and 100-pair protector panels equipped with 110-type connecting blocks and/or RJ21X connectors.

Installing the data link protector

The maximum range for out-of-building digital telephones is 3400 feet when using 24 AWG (#5) (0.5 square millimeters) wire and 2,200 feet (670 meters) when using 26 AWG (#4) (0.4 square millimeters) wire. The range can be extended to 5,000 feet (1,524 meters) using 24 AWG (#5) wire or 4,000 feet (1,220 meters) using 26 AWG (#4) wire with the use of a data link protector. The protector is an isolating transformer used to remove phantom power on the media gateway side and re-introduce it on the terminal side.

When a protector is used, the telephone must be locally powered by an external power supply or through the AC power cord provided with some telephones. The protector is installed on the equipment side of the protection in both buildings.

See [Figure 41: Example adjunct power connections](#) on page 85 and [Figure 46: Connections at trunk/auxiliary field](#) on page 96.

Figure 46: Connections at trunk/auxiliary field

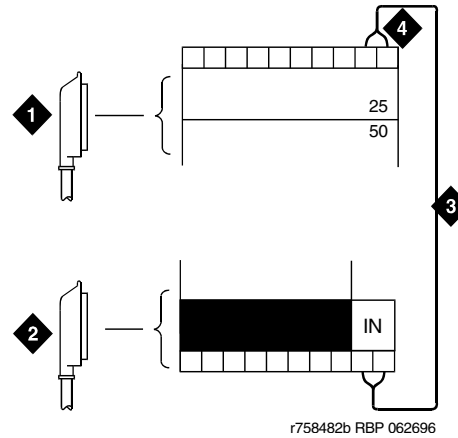

Figure notes:

- | | |
|--|--|
| 1. To Network Interface Facility | 3. One Pair of Wires |
| 2. To Control Carrier Auxiliary Connector | 4. 24th Pair of RJ21X Network Interface Jack |

Emergency transfer units and associated telephones

An 808A Emergency Transfer Panel mounted next to the trunk/auxiliary field provides emergency transfer capability. You can use 2500-series analog telephones either for emergency transfer or as normal extensions. For emergency transfer, connect the phones directly to the 808A; for normal extensions, wire them through the 808A. Analog central office (**CO**) and Wide Area Telecommunications Service (**WATS**) trunks can provide emergency transfer capability.

The 808A Emergency Transfer Panel provides emergency trunk bypass or power-fail transfer for up to five incoming **CO** trunk loops to five selected station sets. The 808A equipment's Ringer Equivalency Number (REN) is 1.0A.

At the MDF, the unit is controlled by a connection to a yellow terminal row/connecting block in the trunk/auxiliary field. The unit is controlled by -48 VDC from the EM TRANS RELAY PWR terminals. There is one EM TRANS RELAY PWR terminal pair that allows powering one transfer unit. This wire pair (in the DB9 alarm cable) is connected to the TN2312BP adapter in only the A-level carrier. Therefore, the G650 Media Gateway only supports one 808A per G650 port network.

Should power be restored to the relays while a call connected through the 808A is in progress, the 808A maintains the connection until the user goes on-hook. Each 808A can handle up to five **CO** trunks.

808A Emergency Transfer Panel and telephone installation examples

[Figure 47: 808A Emergency Transfer Panel](#) on page 98 shows a typical 808A Emergency Transfer Panel. The 808A connects to the MDF with B25A or A25B cable.

The panel can be installed on any mounting frame in either a vertical or horizontal position. The housing has ears for screw-mounting and cutouts for snap-mounting the unit in an 89-type mounting bracket. See [Figure 48: 808A Emergency Transfer Panel mounting](#) on page 99.

Task List: Typical Emergency Transfer Panel and Telephone Installation:

- [Installing the 808A Emergency Transfer Panel](#) on page 99
- [Installing telephones used only for emergency transfer \(trunk/auxiliary field\)](#) on page 104
- [Installing telephones used for emergency transfer and as normal extension \(trunk/auxiliary field\)](#) on page 105

Figure 47: 808A Emergency Transfer Panel

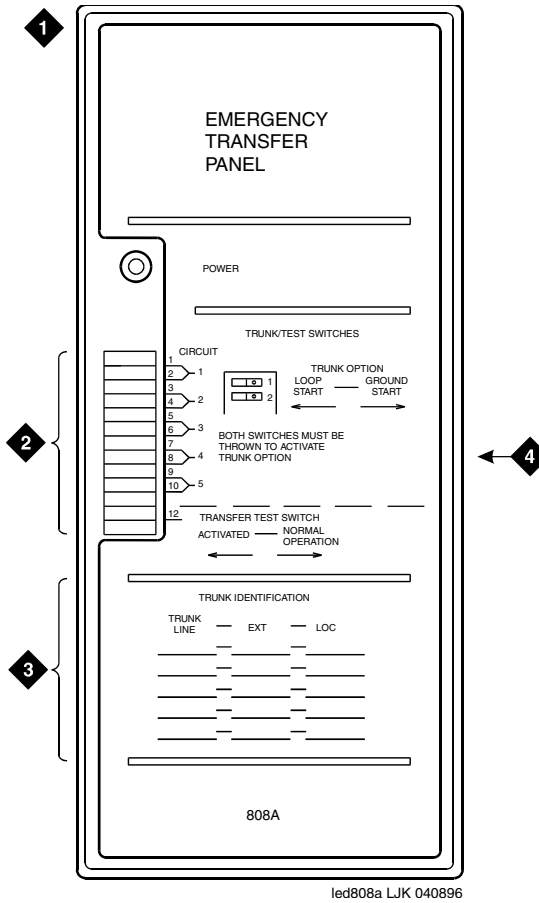
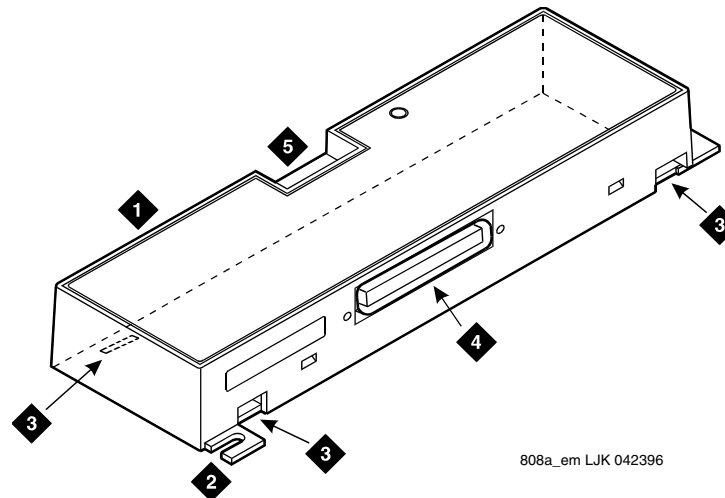

Figure notes:

- | | |
|--|---|
| <p>1. 808A Emergency Transfer Panel</p> <p>2. Circuit Start Selection Switches</p> | <p>3. Trunk Identification Label</p> <p>4. 25-Pair Male Connector</p> |
|--|---|

Figure 48: 808A Emergency Transfer Panel mounting
**Figure notes:**

- | | |
|---|--|
| <ul style="list-style-type: none"> 1. 808A Emergency Transfer Panel 2. Ear for Screw Mount 3. Cut-Out for Snap Mount | <ul style="list-style-type: none"> 4. 25-Pair Male Connector 5. Circuit Start Switches |
|---|--|
-

Installing the 808A Emergency Transfer Panel

Note:

The 808A must be installed in a location that can be accessed only by authorized personnel. The location must meet standard environmental considerations such as temperature, humidity, and so forth.

To install the 808A Emergency Transfer Panel:

1. Verify dial tone is present at each trunk circuit.
2. Locate the circuit start selection switches (see [Figure 47: 808A Emergency Transfer Panel](#) on page 98).

These are the first 10 two-position switches on the left side of the Emergency Transfer Panel. They are used to set each of the five incoming trunk lines to either loop start or ground start. Two switches are used for each circuit; switches 1 and 2 are used for circuit 1, switches 3 and 4 are used for circuit 2, and so forth. See [Table 17: Trunk/test switches](#) on page 101.

3. For loop start, set the switches to the left. For ground start, set the switches to the right.

Installing and wiring telephones and trunks

4. Connect a 25-pair cable between the male RJ21 25-pair connector on the Emergency Transfer Panel and the yellow field of the MDF. [Table 18: Pin assignments for 25-pair connector](#) on page 101 shows the pinouts.

5. Make cross-connections for each emergency trunk/emergency station pair.

The 808A is connected to the MDF by means of a B25A cable. [Figure 49: Connections for telephone used for emergency transfer](#) on page 103 shows the connections at the trunk/auxiliary field for a telephone used only for emergency transfer.

[Figure 50: Connections for telephone used for emergency transfer and as normal extension](#) on page 104 shows the connections at the trunk/auxiliary field for a telephone used for emergency transfer as well as a normal extension.

The auxiliary field for a G650 connects via the DB9 alarm cable to the TN2312BP adapter in the "A" carrier only. See [Figure 42: IPSI-2 cabling](#) on page 88 and [Figure 43: Sample Issue 1 IPSI-2 alarm cable connectivity](#) on page 89.

6. On the trunk identification label at the bottom of the panel, record the trunk line, extension, and location for each circuit.

7. To each telephone designated as an emergency terminal, attach a label identifying it as such. The labels are provided with the unit.

8. Check for normal operation as follows:

- Place the test switch (switch 12) in NORMAL OPERATION.
- Ensure the power supply is providing -48 VDC at 80 mA maximum. The power **LED** should be ON.
- Check wiring connections.
- Verify there is dial tone on all emergency transfer sets.

If all of the above conditions are not met, remove the panel from service and replace it with a new panel.

9. Check for transfer operation as follows:

- Place the test switch (switch 12) in the ACTIVATED position.
- The power LED should be OFF.
- Verify there is dial tone on all emergency transfer sets.

If all of the above conditions are not met, remove the panel from service and replace it with a new panel.

Table 17: Trunk/test switches

Switch number	Circuit number
1	1
2	1
3	2
4	2
5	3
6	3
7	4
8	4
9	5
10	5
11	Not Used
12	Test Switch

Table 18: Pin assignments for 25-pair connector

26	W-BL	TTC1	Tip- PBX Trunk Circuit 1
1	BL-W	RTC1	Ring- PBX Trunk Circuit 1
27	W-O	TTK1	Tip- CO Trunk Circuit 1
2	O-W	RTK1	Ring- CO Trunk Circuit 1
28	W-G	TLC1	Tip- PBX Line Port 1
3	G-W	RLC1	Ring- PBX Line Port 1
29	W-BR	TST1	Tip-Emergency Terminal 1
4	BR-W	RST1	Ring-Emergency Terminal 1
30	W-S	TTC2	Tip- PBX Trunk Circuit 2
5	S-W	RTC2	Ring- PBX Trunk Circuit 2
31	R-BL	TTK2	Tip- CO Trunk Circuit 2
6	BL-R	RTK2	Ring- CO Trunk Circuit 2

1 of 3

Table 18: Pin assignments for 25-pair connector (continued)

32	R-O	TLC2	Tip- PBX Line Port 2
7	O-R	RLC2	Ring- PBX Line Port 2
33	R-G	TST2	Tip-Emergency Terminal 2
8	G-R	RST2	Ring-Emergency Terminal 2
34	R-BR	TTC3	Tip- PBX Trunk Circuit 3
9	BR-R	RTC3	Ring- PBX Trunk Circuit 3
35	R-S	TTK3	Tip- CO Trunk Circuit 3
10	S-R	RTK3	Ring- CO Line Port 3
36	BK-BL	TLC3	Tip- PBX Line Port 3
11	BL-BK	RLC3	Ring-PBX Line Port 3
37	BK-O	TST3	Tip-Emergency Terminal 3
12	O-BK	RST3	Ring-Emergency Terminal 3
38	BK-G	TTC4	Tip- PBX Trunk Circuit 4
13	G-BK	RTC4	Ring- PBX Trunk Circuit 4
39	BK-BR	TTK4	Tip- CO Trunk Circuit 4
14	BR-BK	RTK4	Ring- CO Trunk Circuit 4
40	BK-S	TLC4	Tip- PBX Line Port 4
15	S-BK	RLC4	Ring- PBX Line Port 4
41	Y-BL	TST4	Tip-Emergency Terminal 4
16	BL-Y	RST4	Ring-Emergency Terminal 4
42	Y-O	TTC5	Tip- PBX Trunk Circuit 5
17	O-Y	RTC5	Ring- PBX Trunk Circuit 5
43	Y-G	TTK5	Tip- CO Trunk Circuit 5
18	G-Y	RTK5	Ring- CO Trunk Circuit 5
44	Y-BR	TLC5	Tip- PBX Line Port 5
19	BR-Y	RLC5	Ring- PBX Line Port 5
45	Y-S	TST5	Tip-Emergency Terminal 5
20	S-Y	RST5	Ring-Emergency Terminal 5
46	V-BL	COM1	Common 1 Relay Contact
21	BL-V	NO1	Normally Open 1 Contact

Table 18: Pin assignments for 25-pair connector (continued)

47	V-O	NC2	Normally Closed 2 Contact
22	O-V	NC1	Normally Closed 1 Contact
48	V-G	COM2	Common 2 Relay Contact
23	G-V	NO2	Normally Open 2 Contact
49	V-BR		
24	BR-V		
50	V-S	GRD	Ground from Aux Cable
25	S-V	-48PX	-48V from AUX Cable

3 of 3

Figure 49: Connections for telephone used for emergency transfer

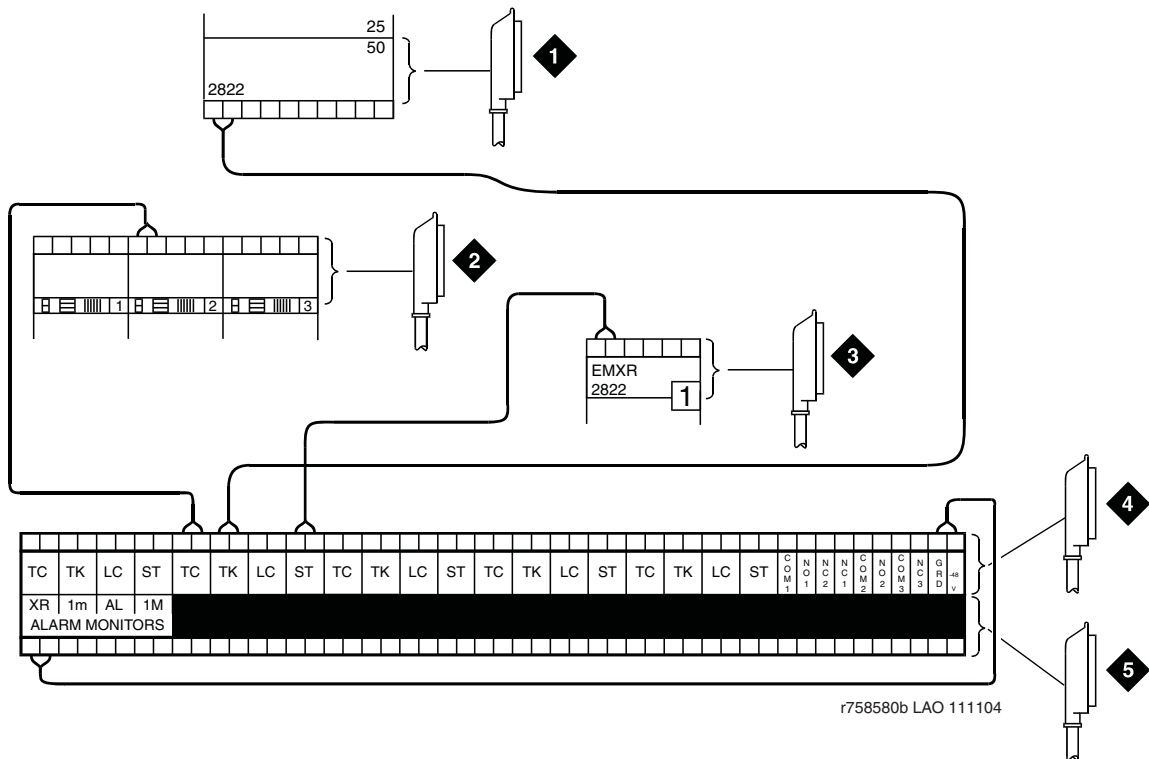
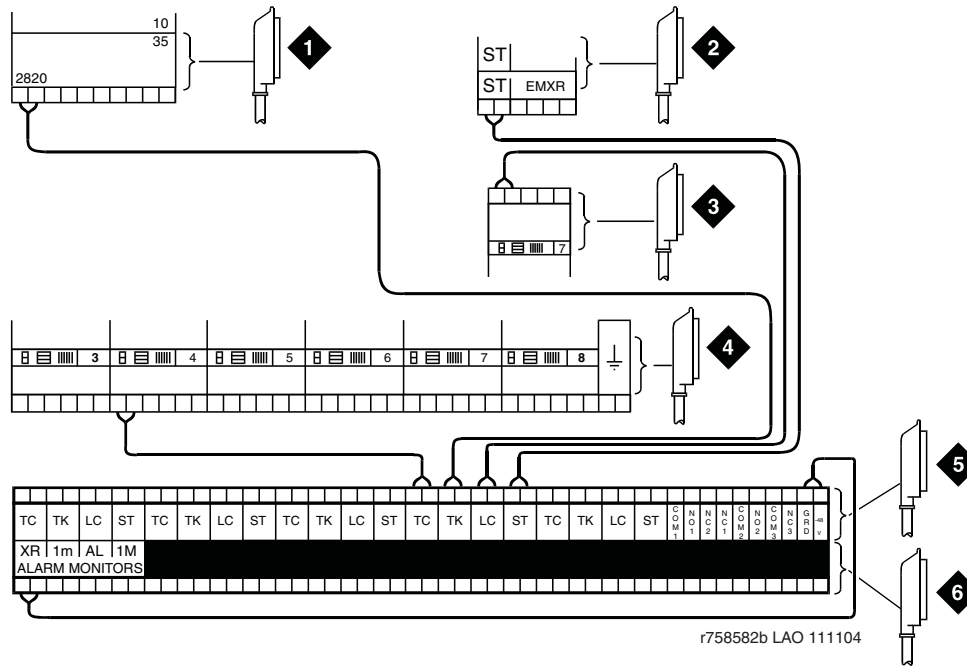

Figure notes:

- | | |
|---|---|
| <ul style="list-style-type: none"> 1. To Network Interface Circuitry 2. To TN747B (or Equivalent) Central Office Trunk Circuit Pack 3. To Blue or White Station Distribution Field | <ul style="list-style-type: none"> 4. To Power Transfer Unit 5. DB9 Alarm Cable to TN2312BP Adapter |
|---|---|

Figure 50: Connections for telephone used for emergency transfer and as normal extension



r758582b LAO 111104

Figure notes:

- | | |
|---|---|
| <ul style="list-style-type: none"> 1. To Network Interface Facility 2. To Blue or White Station Distribution Field 3. To TN2183 or Equivalent Analog Line Circuit Pack | <ul style="list-style-type: none"> 4. To TN747B (or Equivalent) Central Office Trunk Circuit Pack 5. To Power Transfer Unit 6. DB9 Alarm Cable to TN2312BP Adapter |
|---|---|

Installing telephones used only for emergency transfer (trunk/auxiliary field)

To install telephones used only for emergency transfer:

1. Connect a pair of wires between the **-48V** and **GRD** terminals on the yellow emergency transfer row/connecting block and the **EM TRANS RELAY PWR** terminal. See [Figure 49: Connections for telephone used for emergency transfer](#) on page 103.
2. Connect **CO** trunk leads from the purple field to **TC** terminals on the yellow emergency transfer row/connecting block for each trunk.
3. Connect **CO** trunk leads from the green field to **TK** terminals on the yellow emergency transfer row/connecting block for each trunk.

4. Connect **ST** leads on the yellow emergency transfer row/connecting block for each emergency transfer telephone to the assigned terminal in the blue or white station distribution field. The **ST** terminal leads should be terminated on the following pairs: 1, 4, 7, 10, 13, 16, 19, or 22 (the first pair of any 3-pair group).
5. Install the telephone:
 - Connect telephone to the information outlet.
 - Install patch cords/jumper wires between the media gateway side and the station side of the station distribution field on the MDF.

Installing telephones used for emergency transfer and as normal extension (trunk/auxiliary field)

To install telephones used for emergency transfer and as a normal extension:

1. Connect a pair of wires between the **-48V** and **GRD** terminals on the yellow emergency transfer row/connecting block to the **EM TRANS RELAY PWR** terminal. See [Figure 50: Connections for telephone used for emergency transfer and as normal extension](#) on page 104.
2. Connect **CO** trunk leads from the purple field to **TC** terminals on the yellow emergency transfer row/connecting block for each trunk.
3. Connect **CO** trunk leads from the green field to **TK** terminals on the yellow emergency transfer row/connecting block for each trunk.
4. Connect telephone leads from the purple analog line circuit pack row/ connecting block to the **LC** terminals on the yellow emergency transfer row/connecting block for each telephone.
5. Connect **ST** leads on the yellow emergency transfer row/connecting block for each emergency transfer telephone to the assigned terminal in the blue or white station distribution field.
6. Install the telephone:
 - Connect telephone to the information outlet.
 - Install patch cords/jumper wires between the media gateway side and the station.

Installing external ringing

Connections for external ringing are at an information outlet. The media gateway side of the MDF is connected to a TN2183 (or equivalent) Analog Line circuit pack. The circuitry and power source for the device are provided by the customer.

Note:

A maximum of three devices can connect to one analog line circuit pack port.

To install external ringing:

1. Wire the ringing device to the information outlet as shown in [Figure 51: 3-pair and 4-pair modularity](#) on page 106 and [Figure 41: Example adjunct power connections](#) on page 85.
2. Administer per the *Administrator Guide for Avaya Communication Manager* (03-300509).

Figure 51: 3-pair and 4-pair modularity

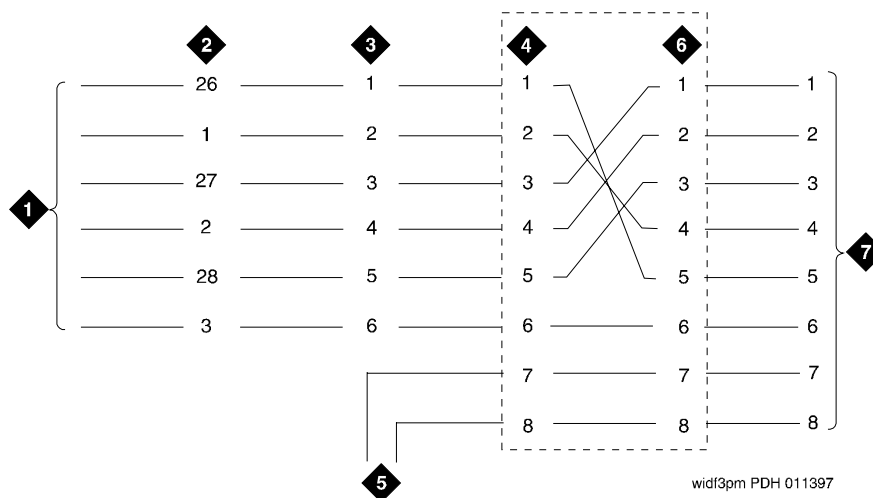

Figure notes:

- | | |
|--|---|
| <ol style="list-style-type: none"> 1. Port Circuit Pack 2. Media Gateway Connector Pins (3-Pair Modularity) 3. Main Distribution Frame (MDF) Pins (3-Pair Modularity) | <ol style="list-style-type: none"> 4. Input to Information Outlet (4-Pair Modularity) 5. Adjunct Power 6. Output From Information Outlet (4-Pair Modularity) 7. Voice or Data Terminal Pins |
|--|---|

Installing the queue warning indicator

The connections for the queue warning indicator are the same as external ringing. An AC indicator (lamp) such as a 21C49 can be used in a uniform call distribution/direct departmental calling (UCD/**DDC**) queue.

The lamp is connected to an information outlet. The media gateway side of the MDF is connected to an analog line circuit pack located in a port carrier.

- Wire the queue warning indicator to the information outlet as shown in [Figure 51: 3-pair and 4-pair modularity](#) on page 106 and [Figure 41: Example adjunct power connections](#) on page 85.

Installing and wiring telephones and trunks

Chapter 7: Installing and wiring telephone power supplies

This section provides information and wiring examples of installation procedures for various telephone and console power supplies. These are examples only and actual wiring procedures may vary at each site.

Note:

See *Adding New Hardware for Avaya Servers and Gateways* (03-300684) to install the necessary peripheral equipment.

The power is provided to telephones or consoles either locally or centrally.

Centrally located power supplies include

- [1145B2 power supply](#) on page 109
- [1152A1 Mid-Span Power Distribution Unit](#) on page 119
- [1152B Mid-Span Power Distribution Units](#) on page 123
- [C360 converged stackable switches](#) on page 128

Local power supplies include

- [1151B1 and 1151B2 Power Supplies](#) on page 131

1145B2 power supply

The 1145B2 closet power arrangement provides an uninterruptible -48 VDC power source with battery and 1146B2 distribution unit for ISDN/DCP, terminal equipment, adjuncts, and other customer-supplied equipment. During **AC** power interruptions, batteries automatically provide power to the load. Although this power supply is available, we recommend that you use the 1151B1 or 1151B2 power supplies.

Note:

Before you begin, read this [Important warning for 1145B2 power supply](#) on page 110.

Perform these tasks in order:

1. [Mounting the 1145B2/1146B2 power supply](#) on page 111
2. [Installing the wall-mounting plates](#) on page 114
3. [Mounting the 1146B2 Power Distribution Unit](#) on page 114

Installing and wiring telephone power supplies

4. [Installing the battery mounting/wiring](#) on page 115
5. [Installing the expanded power distribution unit](#) on page 115
6. [Powering up and testing the power supply](#) on page 116
7. [Wiring the 1146B2 Power Distribution Unit](#) on page 117
8. [Resetting LEDs on power distribution unit](#) on page 118

Important warning for 1145B2 power supply

WARNING:

Important Safety Instructions follow.

When operating this equipment, basic safety precautions must be followed to reduce the risk of fire, electric shock and personal injury, including the following:

- Read and understand all instructions.
- Do not attach the power supply cord to building surfaces.
- For continued back-up protection and battery reliability, replace batteries every four years.
- Follow all warnings and instructions marked on the products.
- Clean products only with a dry rag.
- Do not use this product near water.
- For mounting security, follow all installation instructions when mounting product.
- Openings on top and bottom of power unit are provided for ventilation. Do not block or cover these openings. Do not exceed recommended environmental temperatures.
- Operate these products only from the type of power source indicated on the product labels.
- The power unit is equipped with a 3-wire grounding plug; a plug having a third (grounding) pin. This plug will only fit into a grounding power outlet. This is a safety feature. If you are unable to insert the plug into the outlet, contact an electrician to replace the outlet. Do not defeat the safety purpose of the grounding plug.
- Do not allow anything to rest on or spill into the products.
- To reduce risk of fire and electrical shock, do not overload power outlets.
- Never push objects of any kind through the power supply or distribution unit slots as they may touch dangerous voltage points or short out parts that could result in a risk of fire or electrical shock.
- To reduce risk of electric shock, do not disassemble these products. Return them for repair when needed. Opening or removing covers may expose you to dangerous voltages or other risks. Incorrect reassembly can cause electric shock when the products are subsequently used.

- Power down the power unit (see label on power unit on how to do this) and refer servicing under the following conditions:
 - If liquid has been spilled into any of the products
 - If any of the products have been exposed to water
 - If any of the products do not operate normally
 - If any of the products have been dropped or damaged
 - If any of the products exhibits a change in performance
- Do not attempt to recharge batteries on your own. The batteries may leak corrosive electrolyte or explode. The 1145B2 power unit recharges the batteries safely.
- Remove the batteries if the power unit will not be used for a long period of time (several months or more) since during this time the battery may leak.
- Discard discharged batteries as soon as possible. Discharged batteries are more likely to leak.
- Do not store batteries in high temperature areas. Batteries stored in a cold environment should be protected from condensation during storage and warming. Batteries should be stabilized at room temperature prior to use after cold storage. Do not install batteries if the manufacturing date on the label indicates that the batteries are more than six months old.

Mounting the 1145B2/1146B2 power supply

[Figure 52: 1145B2/1146B2 mounting arrangement](#) on page 112 shows how the standard power supply and wall-mounting plates fit together. [Figure 53: Expanded power distribution unit](#) on page 113 shows the expanded power supply components (power distribution unit and “T” cable).

A manual switch on the distribution unit allows the user to redirect reserve power to outputs 1 through 32 so all outputs are provided battery reserve power or to outputs 1 through 8 to provide high power above 6.25 watts.

Note:

The switch must be set to the 1-32 position.

The 1145B22/1146B2 is a -48 V power supply with 275 watts total output. Each output circuit is current limited by a Polymer Positive Temperature Coefficient Resistance Device (PTC) that limits the maximum output to 12 watts. Each 1146B2 output has an **LED** to indicate the status of the PTC. If the **LED** is on, the PTC has a short on that power pair.

Not all outputs can simultaneously provide 12 watts. The average power per output cannot exceed 8.6 watts ($275/32 = 8.6$). The 1145B22 is designed to power one **ISDN** terminal or DCP adjunct per output. The maximum number of terminals or adjuncts is 32 at less than or equal to 6.25 watts each. The 1145B22 is required for installations outside the United States.

Auxiliary power (local or bulk) is always required for the following:

- Attendant Console 302D
- PassageWay adapter interface

Figure 52: 1145B2/1146B2 mounting arrangement

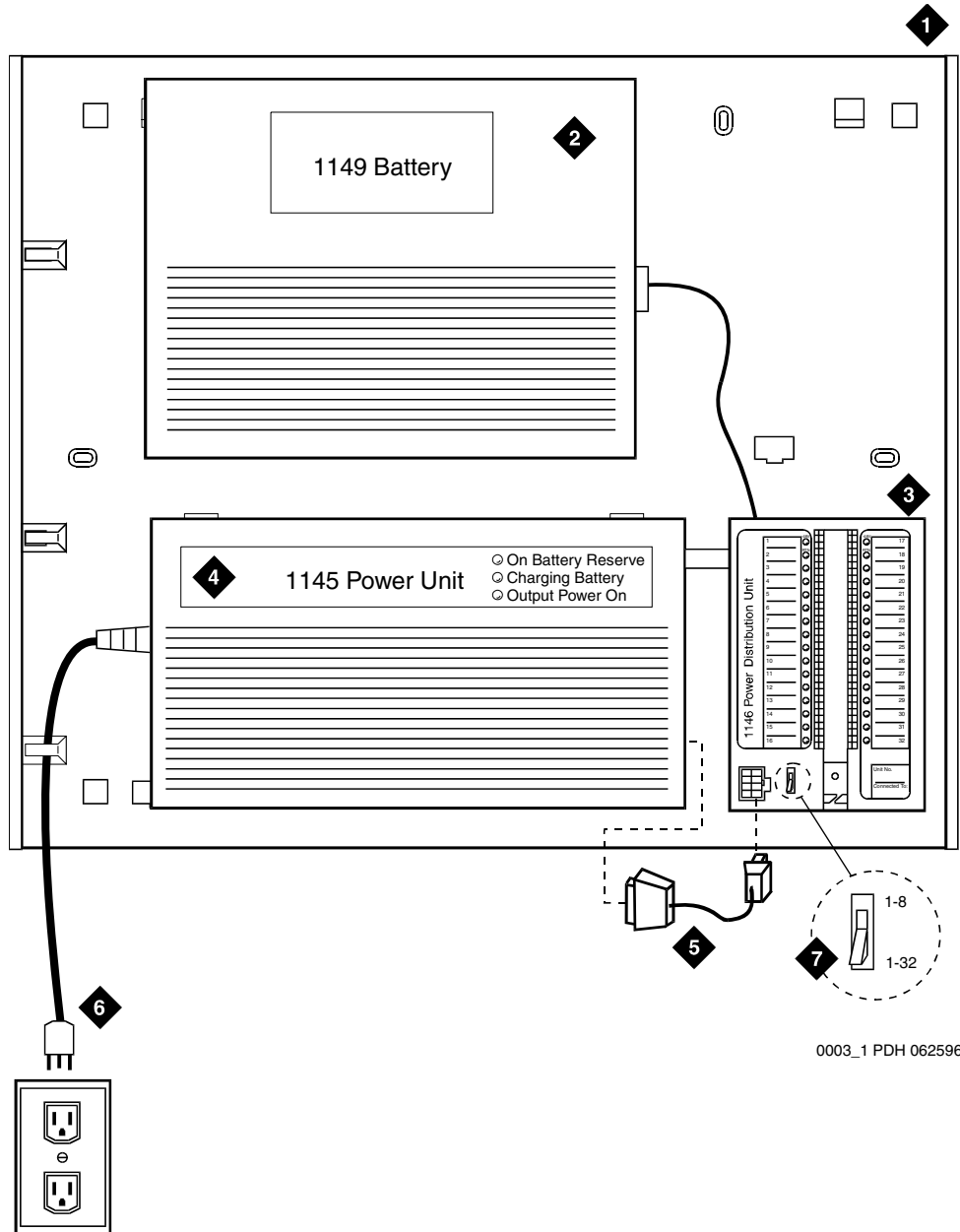

0003_1 PDH 062596

Figure notes:

- | | |
|-----------------------------------|--|
| 1. Wall Mounting Plate | 5. Power Cable |
| 2. Battery (1149B Shown) | 6. Nonswitched Outlet (120 VAC, 20 amp or 230 VAC, 15 amp) |
| 3. 1146B2 Power Distribution Unit | 7. Battery Backup Switch Setting |
| 4. 1145B2 Power Unit | |

Figure 53: Expanded power distribution unit

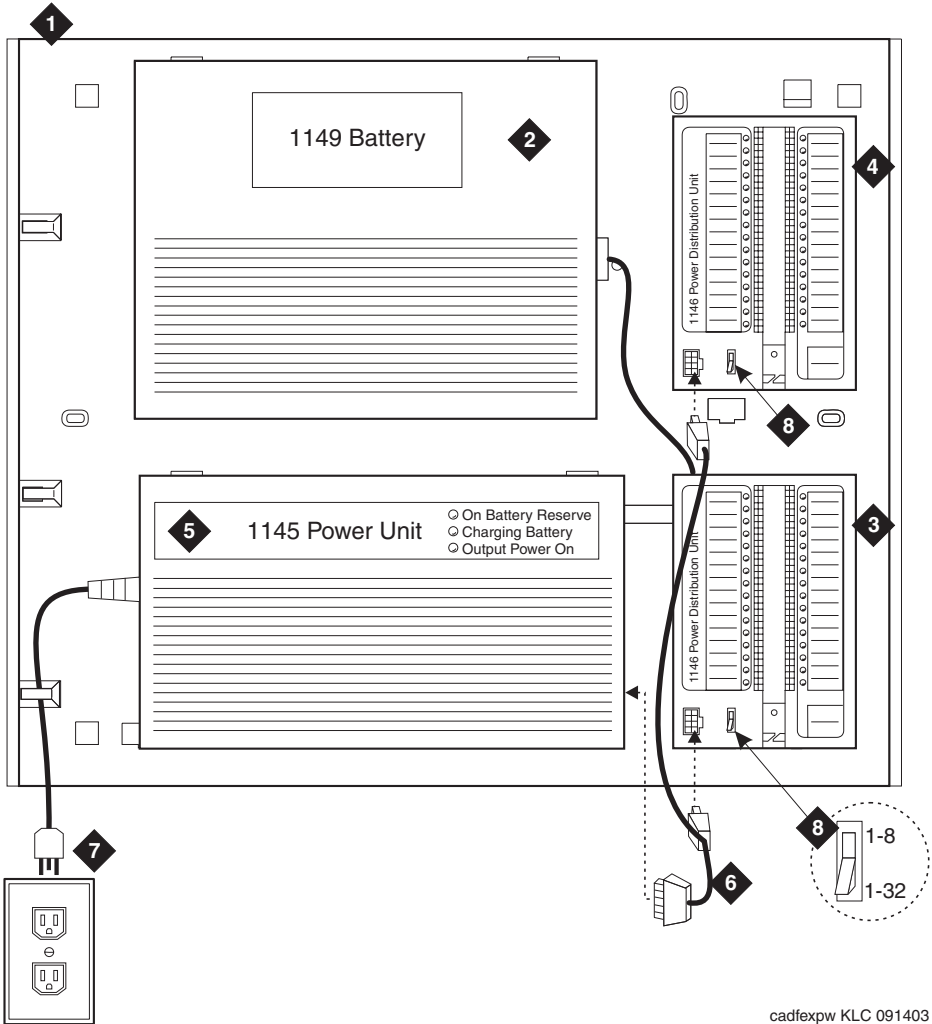

cadfexpw KLC 091403

Figure notes:

- 1. Wall Mounting Plate
- 2. Battery (1149B shown)
- 3. Second 1146B2 Power Distribution Unit
- 4. "T" Cable (H600-347-G7)
- 5. First 1146B2 Power Distribution Unit
- 6. 1145B2 Power Unit
- 7. Nonswitched Outlet (120 VAC, 20 amp or 230 VAC, 15 amp)
- 8. Battery Backup Switch Setting

Installing the wall-mounting plates

The top plate is used for mounting the back-up battery. The bottom plate is used to mount the power supply and distribution units. The plates can be rack-mounted using standard rack-mounting brackets. See [Figure 52: 1145B2/1146B2 mounting arrangement](#) on page 112.

To install the wall-mounting plates:

1. Locate one plate directly below the other one such that the **AC** power cord (6.5 feet [2 meters]) reaches the electrical outlet from a power supply mounted on the bottom plate. Both plates should be located so the raised letters are right side up.

Note:

A maximum of four power supplies can be powered from one dedicated 110 VAC, 20 amperes (or 230 VAC, 15 amperes) feeder. Use only nonswitched outlets (outlets not connected to a wall switch).

2. Secure the wall mounting plates to a standard 3/4-inch (2 centimeters) thick plywood mounting board. Each mounting plate comes with four #10 x 1/2-inch wood screws.
3. The 1145B2 Power Supply is snap-fit onto the bottom wall mounting plate without tools.
4. An installer-provided insulated ground wire, 16 AWG (#12) (1.2 square millimeters) or greater, is required to connect the power supply frame ground lug to an approved ground. The frame ground screw is located next to the **AC** outlet, to the left of the unit.

Mounting the 1146B2 Power Distribution Unit

See the 1146B2 Power Distribution Unit in [Figure 53: Expanded power distribution unit](#) on page 113. To mount the 1146B2 Power Distribution Unit:

1. Insert and securely tighten the two supplied #8-32 x 1/2-inch shoulder screws (they have an unthreaded section at the top) into the top holes designated for 1146B2 Power Distribution Unit on the bottom plate. Mount the unit on these two shoulder screws, using the key holes on the back of the unit.
2. Secure the unit by inserting the #8-32 x 1-inch screw through the bottom of the unit (just above the wire clips) into the plate and tighten.
3. Set the battery back-up switch option to the 1-32 (down) position to provide battery back-up to all outputs.
4. Connect the power distribution unit to the power supply with the power cable. See the power supply's right-hand label to locate the output power connection.

Installing the battery mounting/wiring

Three types of back-up batteries are used. See [Table 19: Back-up battery rating](#) on page 115 for the battery type and rating. To install the battery mounting and wiring:

1. Insert two #10-32 x 1/2-inch shoulder screws into the top designated battery holes on the wall mounting plate. Lightly screw in but do not tighten.
2. Place the keyhole slots in the battery bracket on these two screws. The battery cord exits from the right of the bracket. Make sure the label on the battery is visible. Tighten the screws securely.
3. Plug the battery cord into the power supply's right rear receptacle. The rear receptacle is indicated on the right label.

Table 19: Back-up battery rating

Battery	Rating
1148B	2.5 amp-hours
1149B	5 amp-hours
1147B	8 amp-hours

Installing the expanded power distribution unit

A second power distribution unit can be installed to provide power to additional devices.

 **CAUTION:**

Total power cannot exceed 275 watts. The maximum ISDN terminal mixture is 24, 7500-series and 24, 8500-series terminals.

The maximum DCP terminal mixture is 24, 7400-series and 24, 8400-series or 64, 8400-series terminals.

The expanded power distribution unit kit contains:

- One 1146B2 Power Distribution Unit
- One "T" Cable
- Two #8-32 x 1/2-in. Shoulder Screws
- One #8-32 x 1-in. Screw
- One spacer bracket

Installing and wiring telephone power supplies

See [Figure 53: Expanded power distribution unit](#) on page 113 while installing the power distribution unit. To install the expanded power distribution unit:

1. Set the spacer bracket onto the mounting plate and secure with the #8-32 x 1/2-inch shoulder screws. The spacer bracket is not shown in the figure but is installed behind the top power distribution unit.
2. Slide the keyhole slots in the power distribution unit over the shoulder screws.
3. Insert the #8-32 x 1-inch screw through the distribution unit, through the spacer bracket, and into the plate. The mounting hole is located just above the wire clip. Tighten the screw securely.
4. Set the battery back-up switch to the 1-32 (down) position.
5. Power-down the 1145B2 unit as described on the label on the side of the unit.
6. Remove the output power cable between the 1145B2 and the 1146B2 units. The cable will not be reused.
7. Connect the P1 connector end of the “T” cable to the bottom power distribution unit. Connect the P2 connector to the top distribution unit. Connect the P3 connector to the 1145B2.
8. Power-up the 1145B2 as described on the label on the side of the unit.

Powering up and testing the power supply

[Table 20: Power supply LEDs](#) on page 116 describes the meaning of the power supply LEDs when lit.

Table 20: Power supply LEDs

LED color	Meaning
Green	Power Supply is providing power
Yellow	Battery is charging
Red	Power Supply is on battery reserve

To power up and test the power supply:

1. Connect the **AC** power cord to the power supply and route the cord to an appropriate **AC** outlet using the clips provided on the unit.

Note:

A maximum of four power supplies can be powered from one dedicated 100–120 V, 50/60 Hz, 20-amp feeder or 200–240 V, 50/60 Hz, 10-amp feeder. Use only nonswitched outlets.

2. Plug the cord into the outlet. This powers up the power supply.
3. Check **AC** operation of the 1145B2 Power Supply by monitoring the LEDs:
 - PASS:** Green and yellow LEDs at the front of the unit should be lit together. See [Table 20: Power supply LEDs](#) on page 116. After the battery reaches full charge (maximum of 20 hours), the yellow LED should go out.
 - FAIL:** If either green or yellow LED is not lit after powering up, check the connections. Test the AC outlet. If power is available and the **AC** power cord and connections are good, replace the power unit.
4. Disconnect the **AC** plug on the power supply; this activates the **DC** supply.
5. Check **DC** (battery back-up) operation of the 1145B2 Power Supply by monitoring the LEDs:
 - PASS:** The red and green LEDs should be lit together. See [Table 20: Power supply LEDs](#) on page 116.
 - FAIL:** If either green or red LED is not lit after disconnecting **AC** power, check the connections. If the connections are good, replace the power unit or batteries.
6. Reconnect **AC** power to the power supply.

Wiring the 1146B2 Power Distribution Unit

Wire endpoints to the 1146B2 while power from the 1145B2 is on. A red LED lights if its associated circuit is connected to shorted wiring or to a shorted telephone. To wire the 1146B2 Power Distribution Unit:

1. Install cross-connect jumpers to wire from the unit (the label shows polarity) to Pins 7 and 8 of the appropriate information outlet. Route the wires through the clip provided on the unit. If a red LED is on, see [Resetting LEDs on power distribution unit](#) on page 118. See [Figure 54: Typical wiring to a telephone](#) on page 118.
2. Mark lead destinations on the label next to each connector. Also mark the Unit Number and Connectivity information on the label.

Figure 54: Typical wiring to a telephone

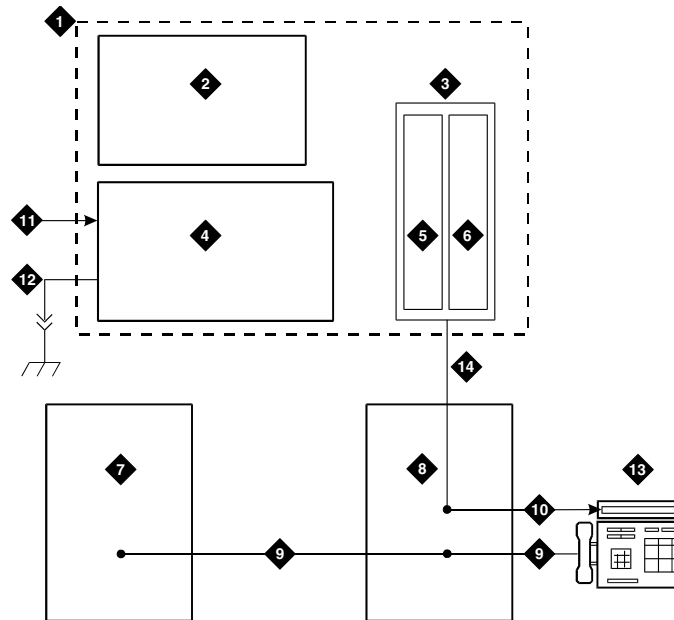

Figure notes:

- | | |
|--------------------------------------|--|
| 1. Power Supply Kit | 9. Modular Cord |
| 2. 2.5, 5.0, or 8.0 Amp Hour Battery | 10. Pins 7 and 8 (Display Terminal Power) |
| 3. 1146B2 Distribution Unit | 11. AC Input |
| 4. 1145B2 Power Supply | 12. Installer-Provided Ground Wire |
| 5. Circuits 1-16 | 13. ISDN/ Display System Protocol Terminal |
| 6. Circuits 17-32 | 14. Circuits 1-32 |
| 7. Port Circuit | |
| 8. Main Distribution Frame | |

Resetting LEDs on power distribution unit

A red LED next to any of the 32 power output connectors indicates a short circuit in the building wiring or the terminal equipment. To reset the LED:

1. Disconnect the terminal equipment from the wall jack.
2. If the LED goes off, the terminal equipment is faulty and must be replaced. If the LED is still lit, find and repair the short circuit in the building wiring.
3. Reconnect the terminal equipment to the wall jack and retest terminal equipment operation.

1152A1 Mid-Span Power Distribution Unit

The 1152A1 Mid-Span Power Distribution Unit (PDU) is an Ethernet power supply that provides power to up to 24 46xx-series IP telephones or wireless LAN (WLAN) access points. This unit is used with a 10/100BaseTx standard Ethernet network over a standard TIA/EIA-568 Category 5, 6 or 6e cabling plant. The 1152A1 meets the current requirements of the IEEE802.3af standard for resistive detection.

The 1152A1 PDU complies with the Underwriters Laboratories Inc. (UL) standard UL 1950, second edition.

Complies	UL 1950
Approved	CSA C22.2 No.950 Std.
Approved	CE Regulatory Compliance
Approved	EN 60950
Approved	TUV EN 60950

For safety instructions, see [Important safety instructions](#) on page 119. For installation instructions, see [Connecting the cables](#) on page 121.

Important safety instructions

Please read the following helpful tips. Retain these tips for later use.

When using this switch, the following safety precautions should always be followed to reduce the risk of fire, electric shock, and injury to persons.

- Read and understand all instructions.
- Follow all warnings and instructions marked on this switch.
- This product can be hazardous if immersed in water. To avoid the possibility of electrical shock, do not use it near water.
- The 1152A1 PDU contains components sensitive to electrostatic discharge. Do not touch the circuit boards unless instructed to do so.
- This product should be operated only from the type of AC (and optional DC) power source indicated on the label. If you are not sure of the type of AC power being provided, contact a qualified service person.
- Do not allow anything to rest on the power cord. Do not locate this product where the cord will be abused by persons walking on it.

Installing and wiring telephone power supplies

- Do not overload wall outlets and extension cords as this can result in the risk of line or electric shock.
- Disconnect the cords on this product and refer servicing to qualified service personnel under the following conditions:
 - If the power supply cord or plug is damaged or frayed.
 - If liquid has been spilled into it.
 - If it has been exposed to rain or water.
 - If it was dropped or the housing has been damaged.
 - If it exhibits a distinct change in performance.
 - If it does not operate normally when following the operating instructions.

Using the 1152A1 Power Distribution Unit

The 1152A1 PDU is used to power the 46xx series of IP telephones in addition to providing 10/100 megabits per second Ethernet connection.

Generation 1 Avaya IP telephones can receive power from the 1152A1 via an in-line adapter. This adapter provides the resistive signature so that the 1152A1 allows power to flow to the telephone. The generation 2 telephones do not need an adapter.

The 1152A1 PDU has 24, 10/100 Base-T ports, each can supply up to 16.8 watts using the internal power supply and operates on a 100-240 VAC, 60/50 hertz power source.

The 1152A1 PDU is 1U high and fits in most standard 19-inch (48-centimeter) racks. It also can be mounted on a shelf. See the user's guide that comes with the unit for complete installation instructions.

Perform these tasks in order:

- [Connecting the 1152A1 Power Distribution Unit](#) on page 120
- [Connecting the cables](#) on page 121

Connecting the 1152A1 Power Distribution Unit



CAUTION:

The 1152A1 PDU has no ON/OFF switch. To connect or disconnect power to the 1152A1 PDU, simply insert or remove the power cable from the AC power receptacle on the rear of the 1152A1 PDU.

To connect the 1152A1 Power Distribution Unit:

1. Plug a power cord into the power socket on the rear of the 1152A1 Power Distribution Unit.
2. Plug the other end of the power cord into the power receptacle.

The 1152A1 PDU powers up, and the internal fans begin operating.

The 1152A1 PDU then runs through its Power On Self Test (POST), which takes less than 10 seconds. During the test, all the ports on the unit are disabled and the LEDs light up. For more information on the test, see the user's guide that comes with the unit.

Connecting the cables

All of the ports on the front of the 1152A1 PDU are configured as data route-through ports for all data wires (pins 1, 2, 3 and 6).

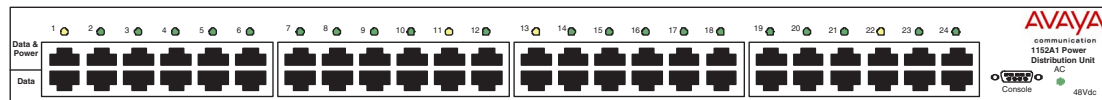

Use a standard CAT5, CAT6 or CAT6e straight-through Ethernet cable (not supplied), including all eight wires (4 pairs) as shown in [Figure 55: Connecting telephones and other end devices to the 1152A1 PDU](#) on page 121.

Figure 55: Connecting telephones and other end devices to the 1152A1 PDU

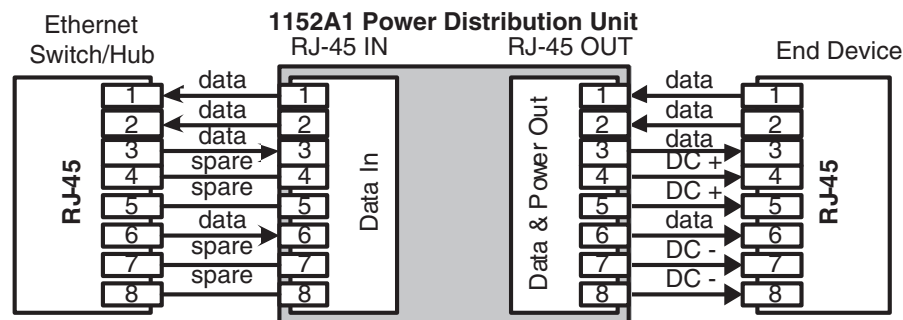

For Data-In ports connect the Ethernet cable leading from the Ethernet Switch/Hub to the Data port. For Data & Power Out ports, connect the Ethernet cable leading to the telephone or other end device to the corresponding Data & Power port.

Note:

Be certain to connect correspondingly numbered Data and Data & Power ports.

Connecting cables to telephones and other end devices

The 1152A1 PDU contains line-sensing capabilities that enable it to send power only to end devices designed to receive power from the LAN. These end devices, termed Power over LAN Enabled, receive power once they are connected to the 1152A1 PDU.

To safeguard devices that are not enabled, the 1152A1 PDU detects devices that are not enabled so does not send power. Note that data continues to flow via the Ethernet cable regardless of the status of the end device.

End devices that are not enabled to receive power directly may receive power and data through an external splitter. The external splitter separates the power and data prior to connection to the end device (see [Figure 56: Connecting an IP telephone with an external splitter](#) on page 122).

Figure 56: Connecting an IP telephone with an external splitter

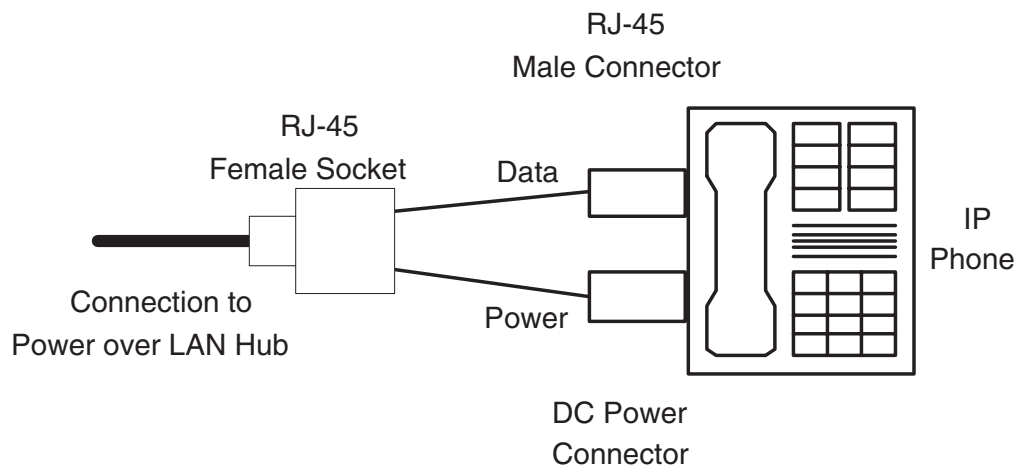

Before connecting telephones or other end devices to the 1152A1 PDU, determine if:

- It is Power over LAN Enabled or not.

If not, you may safely connect the telephone; however, the port supplies no power and functions as a normal Ethernet data port.

- It requires an external splitter or whether it requires only a single RJ45 connection.

If an external splitter is needed, be certain to use a splitter with the correct connector and polarity.

- Its power requirements are consistent with the 1152A1 PDU voltage and power ratings. See Appendix B in the user's guide that comes with the unit for voltage and power ratings.

To connect telephones and other end devices to the 1152A1 PDU:

1. Connect an Ethernet cable to the telephone using an external splitter or directly (if the device is Power over LAN Enabled).
2. Connect the opposite end of the same cable to the RJ45 wall outlet.
3. On the front panel of the 1152A1 PDU, monitor the response of the corresponding port LED. If it lights up GREEN, the unit has identified your telephone as a Power over LAN

1152B Mid-Span Power Distribution Units

The Avaya 1152B Mid-Span Power Distribution Units are Ethernet power supplies that provide power to up to 48 46xx-series or 96xx IP telephones or wireless LAN (WLAN) access points. The 1152B PDUs are designed to deliver power in addition to data communication over an Ethernet network. The 1152B PDUs eliminate the need to connect each Ethernet Data Terminal, such as an IP Telephone set, to an AC power outlet in addition to the data port. The system also removes the need for power cables, local AC wall adapters and the use of a dedicated UPS for each IP telephone. Some models support SNMP remote management via a separate physical RJ45 input port.

These units are used with a standard 10/100BaseTx Ethernet network infrastructure using standard TIA/EIA-568 Category 5, 5e, or 6 100-Ohm Unshielded Twisted Pair (UTP) cable. The 1152B meets the current requirements of the IEEE802.3af-2003 standard for resistive detection.

The units are as follows:

Table 21: 1152B Midspan Power Distribution Units

Avaya Model Number	Number of Ports	SNMP	Summary
1152B48S	48	Yes	48-port, AC Input, 48Vdc Output with SNMP
1152B24S	24	Yes	24-port, AC Input, 48Vdc Output with SNMP
1152B06	6	No	6-port, AC Input, 48Vdc Output
1152B06S	6	No	6-port, AC Input, 48Vdc Output with SNMP

Installing and wiring telephone power supplies

The 1152B PDU complies with the Underwriters Laboratories Inc. (UL) standard UL 60950-1, 1st Edition.

Table 22: 1152B PDU UL 1950 Compliance

Complies	UL 1950
Approved	CAN/CSA-C22.2 No. 60950-1-03Std.
Approved	CE Regulatory Compliance
Approved	EN 60950
Approved	TUV EN 60950

Important 1152B PDU Safety Instructions

Please read the following helpful tips. Retain these tips for later use.

When using this switch, the following safety precautions should always be followed to reduce the risk of fire, electric shock, and injury to persons:

- Read and understand all instructions.
- Follow all warnings and instructions marked on this switch.
- This product can be hazardous if immersed in water. To avoid the possibility of electrical shock, do not use it near water.
- The 1152B PDU contains components sensitive to electrostatic discharge. Do not touch the circuit boards unless instructed to do so.
- This product should be operated only from the type of AC (and optional DC) power source indicated on the label. If you are not sure of the type of AC power being provided, contact a qualified service person.
- Do not allow anything to rest on the power cord. Do not locate this product where the cord will be abused by persons walking on it.
- Do not overload wall outlets and extension cords as this can result in the risk of line or electric shock.
- Disconnect the cords on this product and refer servicing to qualified service personnel under the following conditions:
 - The power supply cord or plug is damaged or frayed
 - Liquid has been spilled into it
 - Exposed to rain or water

- Dropped or the housing has been damaged
- Exhibits a distinct change in performance
- Operates abnormally when following the operating instructions

Using the 1152B PDUs

The 1152B PDUs are used to power the 46xx series and 96xx series of IP telephones in addition to providing 10/100 megabits per second Ethernet connection.

Generation 1 Avaya IP telephones can receive power from the 1152B using an in-line adapter. This adapter provides the resistive signature so that the 1152B allows power to flow to the telephone. The generation 2 telephones do not need an adapter.

The 1152B PDU has 10/100 Base-T ports, each of which can supply a minimum of 15.4 watts using the internal power supply and operates on a 100-240 volts AC, 60/50 hertz power source.

The 1152B PDU is 1U high and fits in most standard 19-inch racks. It can also be mounted on a shelf. Refer to the user's guide that comes with the unit for complete installation instructions.

Connecting the 1152B PDU cables

All of the ports on the front of the 1152B PDU are configured as data route-through ports for all data wires (pins 1, 2, 3 and 6).

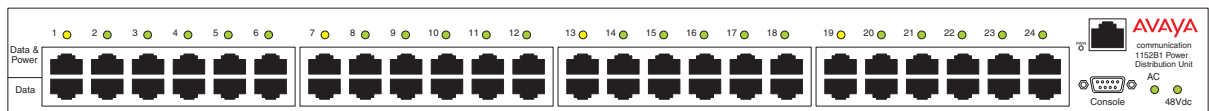

h2cm1152 LAO 122006

Use a standard CAT5, CAT6 or CAT6e straight-through Ethernet cable (not supplied), including all 8 wires (4 pairs) as shown in [Connecting cables to telephones and other end devices](#) on page 126.

Figure 57: Connecting telephones and other end devices to the 1152B PDU

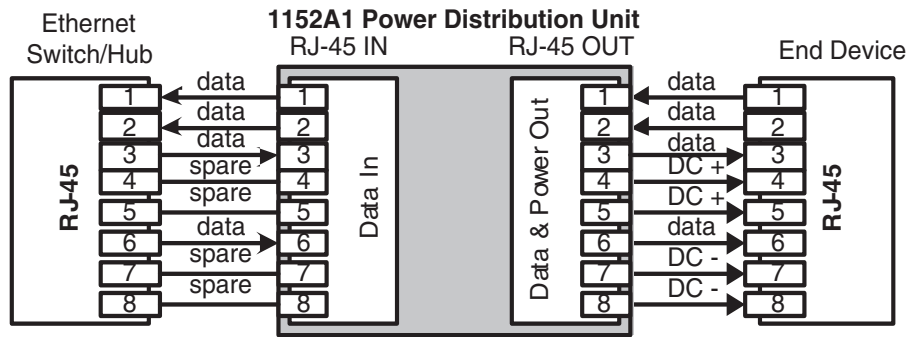

For Data-In ports connect the Ethernet cable leading from the Ethernet Switch/Hub to the Data port. For Data & Power Out ports connect the Ethernet cable leading to the telephone or other end device to the corresponding Data & Power port.

Note:

Be certain to connect correspondingly numbered Data and Data & Power ports.

Connecting cables to telephones and other end devices

An 1152B PDU contains line-sensing capabilities that enables it to send power only to end devices designed to receive power from the LAN. These end devices, termed Power over LAN Enabled, receive power once they are connected to the 1152B PDU.

To safeguard devices that are not enabled, the 1152B PDU detects devices that are not enabled so does not send power. Note that data continues to flow using the Ethernet cable regardless of the status of the end device.

End devices that are not enabled to receive power directly may receive power and data through an external splitter. The external splitter separates the power and data prior to connection to the end device (see [Figure 58: Connecting an IP telephone with an external splitter](#) on page 127).

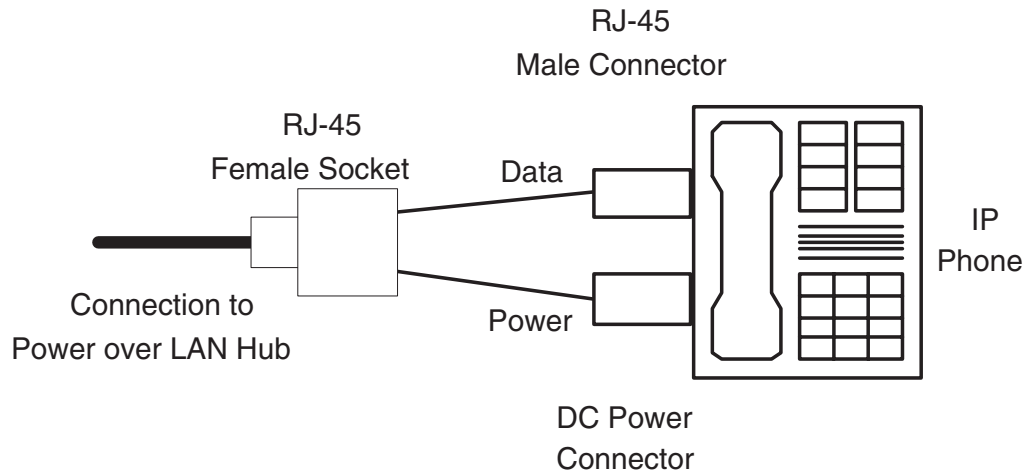
Figure 58: Connecting an IP telephone with an external splitter

Before connecting telephones or other end devices to the 1152B PDU, determine if the device:

- Is Power over LAN Enabled or not.

If not, you may safely connect the telephone; however, the port supplies no power and functions as a normal Ethernet data port.

- Requires an external splitter or whether it requires only a single RJ45 connection.

If an external splitter is needed, be certain to use a splitter with the correct connector and polarity.

- Power requirements are consistent with the 1152B PDU voltage and power ratings.

Refer to Appendix B in the user's guide that comes with the unit for voltage and power ratings.

To connect telephones and other end devices to the 1152B PDU

1. Connect an Ethernet cable to the telephone using an external splitter or directly (if the device is Power over LAN Enabled).
2. Connect the opposite end of the same cable to the RJ45 wall outlet.
3. On the front panel of the 1152B PDU, monitor the response of the corresponding port LED. If it lights up GREEN, the unit has identified your telephone as a Power over LAN telephone.

C360 converged stackable switches

The Avaya C360 series of converged stackable switches include four main products:

C363T	24 10/100BASE-T + 2 GBIC SFP ports
C363T-PWR	24 10/100BASE-T PoE + 2 GBIC SFP ports
C364T	48 10/100BASE-T + 2 GBIC SFP ports
C364T-PWR	48 10/100BASE-T PoE + 2 GBIC SFP ports

The C360 converged stackable switches comply with the Underwriters Laboratories Inc. (UL) standard UL 60950.

Complies	UL 60950
Approved	CSA C22.2 No. 950 Std.
Approved	CE Regulatory Compliance

For safety instructions, see [C360 switch important safety instructions](#) on page 128. For installation instructions, see [Connecting the C360 stackable switches](#) on page 130.

C360 switch important safety instructions

Please read the following helpful tips. Retain these tips for later use.

When using this switch, the following safety precautions should always be followed to reduce the risk of fire, electric shock, and injury to persons.

- Read and understand all instructions.
- Follow all warnings and instructions marked on this switch.
- This product can be hazardous if immersed in water. To avoid the possibility of electrical shock, do not use it near water.
- The Avaya C360 switches and modules contain components sensitive to electrostatic discharge. Do not touch the circuit boards unless instructed to do so.
- This product should be operated only from the type of AC (and optional DC) power source indicated on the label. If you are not sure of the type of AC power being provided, contact a qualified service person.

- Do not allow anything to rest on the power cord. Do not locate this product where the cord will be abused by persons walking on it.
- Do not overload wall outlets and extension cords as this can result in the risk of line or electric shock.
- Disconnect the cords on this product and refer servicing to qualified service personnel under the following conditions:
 - If the power supply cord or plug is damaged or frayed.
 - If liquid has been spilled into it.
 - If it has been exposed to rain or water.
 - If it was dropped or the housing has been damaged.
 - If it exhibits a distinct change in performance.
 - If it does not operate normally when following the operating instructions.

Using the C360 switch

The C360 Stackable Switch can be used to power 46xx series IP telephones in addition to providing a 10/100 megabits per second Ethernet connection. The switch can form part of a stack with the G700 Media Gateway or members of the P330 stackable switching system.

A C360 stack can contain up to 10 switches and up to three backup power supply units. The stacked switches connect using the stacking submodules that plug into a slot in the back of the C360. The X330RC cable connects the top and bottom switches in the stack and provides redundancy and hot-switchability. This characteristic is similar to how modules can be swapped in a modular switching chassis.

Avaya C360 switches are multilayer switches and can be upgraded with a license to provide routing (Layer3) functionality.

The C360 switches can be mounted in a standard 19-inch (48-centimeter) rack or mounted on a wall.

Connecting the C360 stackable switches

Powering up—AC input

To connect the AC input:

1. Insert the power cord into the power inlet on the rear of the unit.
2. Insert the other end of the power cord into the AC power supply.

The unit powers up and performs a self-test procedure. The LEDs flash at regular intervals after the self-test procedure is completed successfully.

3. Connect the BUPS DC power supply (if available).

Powering up—DC input (optional)

The C360 switches can operate on the AC input only. However, you may wish to use the optional DC input for the following:

- Backup for the power over Ethernet ports
- To provide more than 200 watts for the power over Ethernet ports

Note:

Please see the Avaya C360 Manager User Guide and the Quick Start for Hardware Installation Avaya C360 Converged Stackable Switches (03-300148) for more information.

To connect the BUPS DC terminal unit:

1. Remove the protective plastic cover over the BUPS DC inputs by unscrewing the two Phillips screws.

 **WARNING:**

The conductors to be used for connecting the BUPS to the C360 must be UL Recognized and CSA Certified and be a minimum of 16 AWG or have a cross-sectional area of 1.0 mm².

2. Connect the power cable to the terminals on the C360 and then external DC power supply.

 **WARNING:**

Make sure that you connect the cables between the C360 and the external power supply correctly.

- Positive (+) to Positive (+)
 - Negative (-) to Negative (-)
3. Replace the plastic cover by aligning the holes with the screw receptacles and replacing the two Phillips screws.

Connecting the cables

To connect IP telephones, PCs, servers, routers, workstations, and hubs.

1. Connect the Ethernet connection cable (not supplied) to a 10/100 megabits per second port on the front panel of the Avaya C360 series switch.

Note:

Use standard RJ45 connections and a CAT5 cable for 100 megabits per second operation.

2. Connect the other end of the cable to the Ethernet port of the PC, server, router, workstation, IP telephone, switch, or hub.
3. Check that the appropriate link (LNK) LEDs light up.

1151B1 and 1151B2 Power Supplies

The 1151B1 and 1151B2 power supplies are a local power supply. The telephones or consoles connect directly to them through an RJ45 connector. The 1151B2 has a battery backup.

These power supplies comply with the **Underwriters Laboratories Inc. (UL)** Standard UL 60950 third edition.

Complies	UL 60950
Certified	CSA C22.2
Approved	EN
Approved	CE Regulatory Compliance

For safety instructions, see [Important safety instructions for 1151B1 and 1151B2 Power Supplies](#) on page 132. For installation instructions, see [Connecting the 1151B1 or 1151B2 Power Supplies](#) on page 133.

Important safety instructions for 1151B1 and 1151B2 Power Supplies

Please read the following helpful tips. Retain these tips for later use.

When using this power supply, the following safety precautions should always be followed to reduce the risk of fire, electric shock, and injury to persons.

- Read and understand all instructions.
- Follow all warnings and instructions marked on this power supply.
- This product can be hazardous if immersed in water. To avoid the possibility of electrical shock, do not use it near water.
- To reduce the risk of electric shock, do not disassemble this product except to replace the battery.
- This product should be operated only from the type of AC power source indicated on the label. If you are not sure of the type of AC power being provided, contact a qualified service person.
- Do not allow anything to rest on the power cord. Do not locate this product where the cord will be abused by persons walking on it.
- Do not overload wall outlets and extension cords as this can result in the risk of line or electric shock.
- Disconnect the cords on this product and refer servicing to qualified service personnel under the following conditions:
 - When the power supply cord or plug is damaged or frayed.
 - If liquid has been spilled into the product.
 - If the product has been exposed to rain or water.
 - If the product was dropped or the housing has been damaged.
 - If the product exhibits a distinct change in performance.
 - If the product does not operate normally by following the operating instructions.

Using 1151B1 and 1151B2 Power Supplies

The 1151B1 and 1151B2 Power Supplies can be used to supply local power to ISDN-T 85xx and 84xx series and 46xx series telephones connected to a media gateway and to the 302D Attendant Console that requires auxiliary power for its display. The unit can supply power to adjunct equipment such as S201A and CS201A speakerphones or a 500A Headset Adapter attached to any currently manufactured analog, **DCP**, or ISDN-T telephone equipped with an adjunct jack.

⚠ CAUTION:

The power supply can be used *only* with telecommunications equipment, indoors, and in a controlled environment.

The power supply has a single output of -48 VDC, 0.4 amperes and can operate from either a 120 VAC 60 hertz power source (105 to 129 VAC) or a 220/230/240 VAC 50 hertz power source (198 to 264 VAC). Input voltage selection is automatic. The output capacity is 19.2 watts.

The power supply can be placed on a flat surface such as a desk. For wall-mounting, keyhole slots are provided on the bottom of the chassis.

⚠ CAUTION:

Do not locate the unit within 6 inches (15 centimeters) of the floor.

Connecting the 1151B1 or 1151B2 Power Supplies

The 1151B1 is a standard (no battery backup) power supply unit. The 1151B2 is a battery backup version of the 1151B1. Either power supply can support one telephone with or without an adjunct. The maximum loop range is 250 feet (76 meters). Two modular jacks are used. Power is provided on the PHONE jack, pins 7 and 8 (- and +, respectively).

The PHONE and LINE jacks are 8-pin female nonkeyed 657-type jacks that can accept D4, D6, and D8 modular plug cables. See an [Figure 59: 1151B2 Power Supply — front](#) on page 133.

Figure 59: 1151B2 Power Supply — front

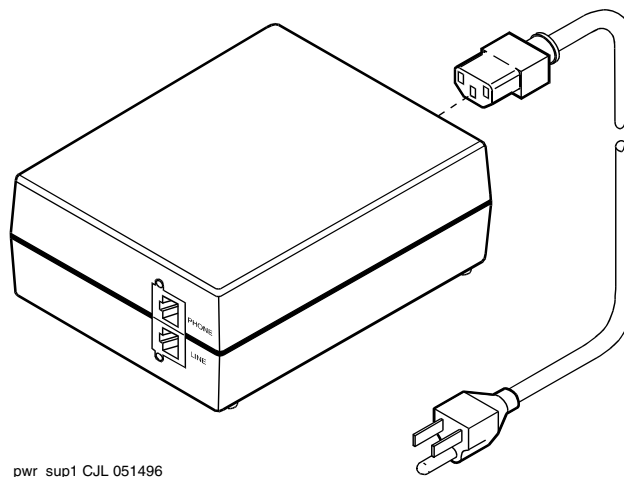

Installing and wiring telephone power supplies

Chapter 8: Testing the complete configuration

This section provides tests for the complete configuration, including the control and signaling networks and the telephones and consoles.

This section provides tests to:

- review the status of the configuration.
- test the duplication link to the servers (S8700-series only)
- test the IP server interfaces, expansion interfaces, and TDM buses in the port networks.
- test the telephones and other equipment.

See [LED indicators](#) on page 147 for information regarding the LED status indicators for the Avaya Ethernet switch(es), uninterruptible power supplies (UPSs), and different circuit packs.

Note:

Circuit pack positions are usually given by cabinet, and slot. They may also be given by port. The term “cabinet” refers to five G650 Media Gateways TDM-cabled together in a rack, making up one port network. A port network is defined as a group of media gateways connected together with one TDM bus.

Perform these tasks to test the configuration:

 **CAUTION:**

To prevent unnecessary trouble tickets, do not enable the alarms (Alarm Origination feature) until all installation and administration procedures are completed.

1. [Testing port network equipment](#) on page 136
2. [Checking port network status for each media gateway](#) on page 136
3. [Checking circuit pack configuration](#) on page 137
4. [Testing the TN2312BP Internet Protocol Server Interface circuit pack](#) on page 138
5. [Testing Expansion Interface circuit packs, if used](#) on page 139
6. [Testing time division multiplexing bus for each port network](#) on page 140
7. [Testing expansion interface exchange, if used, for each port network](#) on page 141
8. [Testing telephones and other equipment](#) on page 142

Testing port network equipment

These tests verify that the time division multiplexing (TDM) cables and terminators work. If a **FAIL** Result code is seen, check these cables. If problems persist, see the maintenance book for your configuration.

Checking port network status for each media gateway

The port network status may suggest problem areas. Tests described later provide more specific diagnostic information.

To check the port network status for each media gateway:

1. Type `status port-network number <1-64>` and press **Enter**.
2. Verify the screen displays a **Port Network Status** screen similar to [Figure 60: Sample port network status screen for Cabinet 1—Avaya S8500](#) on page 137.

Verify these service states:

Field	Service State
TDM Bus A	in
TDM Bus B	in
Tone/Clock	in
PKT	in

Figure 60: Sample port network status screen for Cabinet 1—Avaya S8500

```

status port-network 1
                                PORT NETWORK STATUS

Major  Minor  Warning  Carrier  PN Control  FIBER-
PN Alarms Alarms Alarms  Locs   Active  Standby  LINK      Endpoints  Mode
1      1      0      195    01A    up      up      1 B-PNC 01B02-03E04 standby
                                01B                                1 A-PNC 01A01-01E04 active

TDM Service  Control  Dedicated  TONE/  Service  System  System
Bus State  Channel  Tones      CLOCK  State  Clock  Tones
A  in      y      n      01B  in  standby standby
B  in      n      y      01A  in  active  active

Service  Major  Minor  Bus  Open Bus
PKT State  Alarms Alarms Faults Leads
1      in  n      n      0      0

Command:

```

Checking circuit pack configuration

The list configuration report provides a list of circuit packs connected to the configuration and recognized by the software. To check circuit pack configuration:

1. Type **list configuration all** and press **Enter**.
2. Verify the screen displays list configuration similar to [Figure 61: Sample system configuration screen — Page 4, Avaya S8700 Multi-Connect on page 138](#). Make sure the software is communicating with each circuit pack (except power supply circuit packs). Do not attempt to correct any problems until after the diagnostic tests that you run later in the configuration tests.
3. Note any boards with a **VINTAGE** column entry of **NO BOARD** or **CONFLICT**.
A **u** indicates unassigned ports, and a number indicates the port has been translated.

Figure 61: Sample system configuration screen — Page 4, Avaya S8700 Multi-Connect

```
list configuration all Page 4

                                SYSTEM CONFIGURATION

Board                               Assigned Ports
Number  Board Type                Code   Vintage  u=unassigned t=tti p=psa
-----  -
01B01   IP SERVER INTFC              TN2312BP HW33 FW045 01 02 03 04 05 06 07 08
01B02   EXPANSION INTRFC            TN570C  000002
01B03   DS1 INTERFACE                TN464HP 000020      01 02 03 04 05 06 07 08
                                           09 10 11 12 13 14 15 16
                                           17 18 19 20 21 22 23 24
                                           25 26 27 28 29 30 31 u
01B05   DS1 INTERFACE                TN464HP 000020      01 02 03 04 05 06 07 08
                                           09 10 11 12 13 14 15 16
                                           17 18 19 20 21 22 23 24
                                           25 26 27 28 29 30 31 u
01B06   DS1 INTERFACE                TN464HP 000006      01 02 03 04 05 06 07 08
                                           09 10 11 12 13 14 15 16
                                           17 18 19 20 21 22 23 24
                                           25 26 27 28 29 30 u u

                                press CANCEL to quit -- press NEXT PAGE to continue
```

Testing the TN2312BP Internet Protocol Server Interface circuit pack

To test the TN2312BP Internet Protocol Server Interface circuit pack using Avaya Site Administration:

1. Type `test ipserver-interface uuc` and press **Enter** to test all clock and packet interface components within the IPSI circuit pack.
2. Verify the screen displays **Test Results** screen similar to [Figure 62: Sample IPSI 01A test results screen — Page 1, Avaya S8700 Multi-Connect](#) on page 139.

Figure 62: Sample IPSI 01A test results screen — Page 1, Avaya S8700 Multi-Connect

```

test ipserver-interface 1a                                     Page 1

```

TEST RESULTS						
Port	Maintenance Name	Alt. Name	Test No.	Result	Error Code	
01A	TONE-BD		46	PASS		
01A	TONE-BD		52	PASS		
01A0201	ETR-PT		42	PASS		
01A0201	ETR-PT		43	PASS		
01A0202	ETR-PT		42	PASS		
01A0202	ETR-PT		43	PASS		
01A0203	ETR-PT		42	PASS		
01A0203	ETR-PT		43	PASS		
01A0204	ETR-PT		42	PASS		
01A0204	ETR-PT		43	PASS		
01A0205	ETR-PT		42	PASS		
01A0205	ETR-PT		43	PASS		
01A0206	ETR-PT		42	PASS		
01A0206	ETR-PT		43	PASS		
01A0207	ETR-PT		42	PASS		

press CANCEL to quit -- press NEXT PAGE to continue

Testing Expansion Interface circuit packs, if used

To check each Expansion Interface (EI) circuit pack in the media gateway:

1. Type **test board *UUCSS*** where *UUCSS* is the cabinet, and slot for an EI circuit pack in the media gateway, and press **Enter**.

Note:

Labels on the port network and on the strip under the circuit pack contain this information.

2. Verify the screen displays test results similar to [Figure 63: Sample test results for Expansion Interface Board 2A01 on page 140](#). This example is for board 2a01.
3. If any result is **FAIL**, check the connections for the fiber optic link.
4. Repeat Steps 1 and 2 for each Expansion Interface circuit pack.

Figure 63: Sample test results for Expansion Interface Board 2A01

TEST RESULTS					
Port	Maintenance Name	Alt. Name	Test No.	Result	Error Code
02A01	EXP-INTF		237	PASS	
02A01	EXP-INTF		238	PASS	
02A01	EXP-INTF		240	PASS	
02A01	EXP-INTF		241	PASS	
02A01	EXP-INTF		244	PASS	
02A01	EXP-INTF		316	PASS	

Testing time division multiplexing bus for each port network

To check each TDM bus for each port network (PN) in the configuration.

1. Type `test tdm port-network 1` and press **Enter**.
2. Verify a **Test Results** screen similar to [Figure 64: Sample test results for TDM bus port network 1 on page 140](#) appears.
3. If result is **FAIL** for any test, check the connectors of the TDM bus cables in PN 2.
4. Repeat these steps for each PN to check the TDM bus cables.

Figure 64: Sample test results for TDM bus port network 1

test tdm port-network 1					
TEST RESULTS					
Port	Maintenance Name	Alt. Name	Test No.	Result	Error Code
PN 01A	TDM-BUS		294	PASS	
PN 01A	TDM-BUS		296	PASS	
PN 01A	TDM-BUS		297	ABORT	1005
PN 01B	TDM-BUS		294	PASS	
PN 01B	TDM-BUS		296	ABORT	1005
PN 01B	TDM-BUS		297	PASS	

Testing expansion interface exchange, if used, for each port network

If the configuration is critical reliability, test the expansion interface exchange for each PN:

1. Type `status port-network number <1-64>` and press **Enter**.

This displays the standby expansion link. See [Figure 65: Sample of port network status before expansion link is set on page 141](#).

2. Type `set expansion-link UUCSS`, where *UUCSS* is one of the cabinet, and port locations of the standby expansion link, and press **Enter**.

3. Verify the bottom of the screen displays:

Command successfully completed

4. Type `status port-network number <1-64>` and press **Enter**.

A screen similar to [Figure 66: Sample of port network status after expansion link is set on page 142](#) displays.

5. Verify that the **MODEs** of the expansion links have changed.
6. If any problems are indicated, check the TDM cables and the inter-cabinet cables (ICC) in the associated port network.

Figure 65: Sample of port network status before expansion link is set

```

status port-network
                                PORT NETWORK STATUS

Major      Minor Warning  Carrier  PNC Status  ATM      PNC
PN Alarms  Alarms Alarms    Locs      Active Standby Conn  Endpoints  Mode
1  0       1      19      01A      up        2      A-PNC 01D01-AT02A  active
                                01B      1      A-PNC 01C01-AT01A  active
                                01C
                                01D

TDM Service Control Dedicated      TONE/ Service System System
Bus State Channel Tones          CLOCK State Clock Tones
A  in      n      n          01A  in      standby standby
B  in      y      y          01B  in      active active

Service      Major      Minor      Bus      Open Bus
PKT State    Alarms    Alarms    Faults   Leads
1  in      n      n      0      0

```

Figure 66: Sample of port network status after expansion link is set

```

status port-network
                                PORT NETWORK STATUS

Major  Minor  Warning  Carrier  PN Control  FIBER-
PN Alarms Alarms Alarms  Locs   Active  Standby  LINK      Endpoints  Mode

1      1      0        220    01A    up      up      1  B-PNC  01B02-03E04  standby
                                01B                                1  A-PNC  01A01-01E04  active

TDM Service  Control  Dedicated  TONE/  Service  System  System
Bus State  Channel  Tones     CLOCK  State  Clock  Tones

A  in      y      n      01B  in      standby  standby
B  in      n      y      01A  in      active   active

Service  Major  Minor  Bus  Open Bus
PKT State  Alarms Alarms Faults Leads

1      in      n      n      0      0

Command:
    
```

Saving translations, if required

- Type `save translations` and press **Enter** to save the translations to the hard drive.

Testing telephones and other equipment

This section describes how to test the telephones and other equipment. Perform these tests after the equipment has been wired to the media gateway and after the customer’s data for that equipment has been administered. The tests are acceptance tests and provide some assurance that the system will perform properly after installation and administration.

If problems occur or more extensive tests are required, see the maintenance book for your configuration.

Perform these tasks to complete acceptance tests:

- [Making test calls](#) on page 143
- [Testing 302C attendant console](#) on page 143
- [Testing selector console](#) on page 144

- [Testing external ringing](#) on page 144
- [Testing queue warning indicator](#) on page 144
- [Testing integrated announcement](#) on page 144
- [Testing music-on-hold](#) on page 145
- [Testing emergency transfer \(Avaya S8700 Multi-Connect only\)](#) on page 145
- [Testing terminating trunk transmission](#) on page 146
- [Testing connectivity to the LAN](#) on page 147

Making test calls

Make two calls from one telephone to another telephone. Make the first call by dialing a telephone and make the second call by dialing a trunk access code and a listed directory number (LDN).

Testing 302C attendant console

To check that all lamps are operational and call another telephone in the configuration:

1. Simultaneously press and hold **Ringer Volume up** and **POS BUSY**.

This puts the console in the self-test mode.

Note:

Releasing the buttons returns the console to normal mode.

2. Verify all lamps on display light and remain lighted.

Each row of lamps on the console lights and goes dark in sequence from top to bottom.

3. Press Start and listen for dial tone.

The green lamp associated with Idle Call Appearance lights up.

The Position Available lamp goes dark.

4. Dial a number associated with a working telephone.

Audible ringing tone is heard in ear piece.

5. Press **Release**.

Audible ringing tone is silenced. The green lamp associated with idle call appearance button goes dark. The Position Available lamp lights.

Testing selector console

To check that all selector console lamps are operational and make a call to a telephone in the configuration:

1. Simultaneously press and hold **Ringer Volume up** and **POS BUSY** on the attendant console. This puts the console in the self-test mode.

Each row of lamps on the selector console lights and goes dark in sequence from top to bottom.

2. Press hundreds group select button.

The hundreds group select lamp lights and any lamps associated with busy telephone light.

3. Press **Direct Extension Selection (DXS)** for the desired extension.

Audible ringing tone is heard in the ear piece on attendant console.

4. On attendant console, press **Release**.

Audible ringing tone is silenced.

Testing external ringing

Make a test call to the attendant console to verify ringing device sounds when the Night lamp on console is lighted. If ringing device has not been installed by customer, connect spare telephone to information outlet reserved for ringing device and make test call.

Testing queue warning indicator

Make a test call to an extension associated with a uniform call distribution (**UCD**) or direct department calling (**DDC**) group, and verify the queue warning indicator lamp lights. If the queue warning indicator has not been installed by customer, connect a spare telephone to the information outlet reserved for queue warning indicator and make a test call.

Testing integrated announcement

The TN2501AP Announcement circuit packs provide the ability to store messages. The messages can be recorded from telephones on- or off-premises and have flexible message lengths. The telephone selected as the test telephone must have a class of service (COS) with console permission enabled.

Record an announcement

To record an announcement:

1. Select a test telephone with console permissions enabled.
2. Dial the access code followed by the integrated announcement extension number.
3. When you hear a dial tone, press **1**. When you hear a beep or stutter tone, speak the announcement into the telephone.
4. When done, press **#** if a digital phone or hang up if an analog phone to stop the recording.
You then hear a dial tone.

Playback announcement

To play back an announcement:

1. If using a digital phone, press **2** to hear the announcement. When the announcement is over, you hear a dial tone. If satisfied, hang up.
2. If using an analog phone, dial the integrated announcement extension number to hear the announcement.
When the announcement is over, you hear a dial tone. If satisfied, hang up.

Delete announcement

To delete an announcement:

1. Dial the access code followed by the integrated announcement extension number.
2. When you hear a dial tone, press **3** to delete the announcement and end the recording session.
A confirmation tone is heard when the announcement is deleted.

Testing music-on-hold

Verify music is provided to a held party during any hold interval.

Testing emergency transfer (Avaya S8700 Multi-Connect only)

Put configuration in emergency transfer mode and make call using emergency transfer telephone. There may be up to four Emergency Transfer panels on a wall in the phone closet, depending on the configuration.

Testing terminating trunk transmission

The terminating trunk transmission test provides for extension number access to 3 tone sequences that can be used for trunk transmission testing from the distant end of the trunks. To test terminating trunk transmission:

1. Type `change system-parameters maintenance` and press **Enter** and go to screen 2.
2. Under TERMINATING TRUNK TRANSMISSION TEST (Extension), type in 3 extension numbers in the 3 fields provided:

Test Type 100: _____ Test Type 102: _____ Test Type 105: _____

Test type	Test features
Test type 100	5.5 seconds of 1004 Hz tone at 0 dB Quiet until disconnect; disconnect is forced after 1 minute
Test Type 102	9 seconds of 1004 Hz tone at 0 dB 1 second of silence Cycle is repeated until disconnect, which is forced after 24 hours
Test Type 105	9 seconds of 1004 Hz tone at -16 dB 1 second of silence 9 seconds of 404 Hz tone at -16 dB 1 second of silence 9 seconds of 2804 Hz tone at -16 dB 30 seconds of silence 0.5 seconds of test progress tone (2225 Hz) About 5 seconds of silence Forced disconnect

Testing connectivity to the LAN

To test the external IP connections for the C-LAN, IP Media Processor, and VAL circuit packs, you must ping the circuit pack and ping a known computer connected to your network. If everything is configured correctly, the **Result** column on the **Ping Results** screen reads **PASS**. If it reads **ABORT**, verify the IP-address information and check the connectivity, including the cabling.

To test connectivity to the LAN:

1. Type `ping ip-address IPaddress board UUCSS` and press **Enter**, where the variable *IPaddress* is the IP address of the circuit pack and *UUCSS* is the cabinet, and slot of the circuit pack.
2. Type `ping ip-address IPaddress board UUCSS` and press **Enter**, where the variable *IPaddress* is the IP address of another computer beyond the gateway and *UUCSS* is the cabinet, and slot of the circuit pack.

LED indicators

See the maintenance book for your system for detailed alarm and LED descriptions. If a maintenance object begins to fail some periodic tests, the server will generate an alarm. The server identifies three levels of alarms:

- Major Alarms — Failures that cause critical degradation of service and require immediate attention.
- Minor Alarms — Failures that cause some degradation of service, but do not cause a critical portion of the configuration to be inoperable. This condition requires action, but its consequences are not immediate. Problems might be impaired service to a few trunks or stations or interfering with one feature across the entire configuration.
- Warning Alarms — Failures that cause no significant degradation of service or failures in equipment external to the configuration. Warning alarms are not reported to the attendant console or **INADS**.

Alarms are communicated to users and technicians by entries in the alarm and sys logs and the lighting of **LEDs** located on the attendant console, on all circuit packs, and, optionally, on customer-designated telephones.

More detailed information is available here for:

- [Telephone console LEDs](#) on page 148
- [DS1 Converter circuit pack LEDs](#) on page 148
- [SPAN LEDs](#) on page 150

Telephone console LEDs

Telephones and attendant consoles have some alarm LEDs that must be checked out.

Attendant console LEDs

The console has two red **LEDs**, labeled “ALM” and “ACK”. The ALM LED lights steadily when there is a major or minor alarm at the server. The ACK LED lights steadily if the alarm has been successfully reported to **INADS**. If the server is unable to report the alarm to **INADS**, the **LED** flashes; this signals the attendant to call **INADS** and report the alarm.

Terminal alarm notification

Terminal Alarm Notification is an optional feature that displays several types of alarms on telephones with administered feature buttons or the attendant console. A maximum of 10 digital and/or hybrid telephones may be used.

When an alarm occurs, the green status **LED** associated with the assigned button is in a steady state. The LED may be turned off by pressing the button associated with the LED. If the LED is off and the alarm has not been resolved by the time maintenance reschedules testing, the green status **LED** resumes its steady state.

DS1 Converter circuit pack LEDs

Eleven **LEDs** provide an indication of the state of the [Figure 67: TN1654 DS1 Converter circuit pack LEDs](#) and the T1/E1 facilities. The top group has the standard red, green and yellow LEDs. The red LED indicates an alarm condition and the green LED indicates testing in progress. The four SPAN LEDs indicate the status of the T1/E1 facilities. The four STATUS LEDs currently are unused and remain off.

Figure 67: TN1654 DS1 Converter circuit pack LEDs

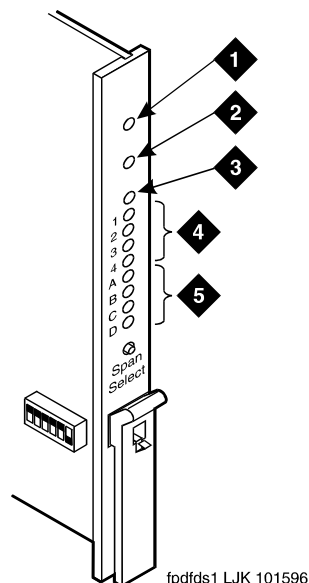

Figure notes:

- | | |
|----------------------|----------------|
| 1. Alarm LED (Red) | 4. STATUS LEDs |
| 2. Test LED (Green) | 5. SPAN LEDs |
| 3. Busy LED (Yellow) | |

The yellow **LED** indicates the state of the fiber interface, the fiber channel, the **control** channel, and the communications link to the SPE in the following manner and order of priority. See [Table 23: DS1 Converter yellow LED flashing states](#).

Table 23: DS1 Converter yellow LED flashing states

LED on	LED off	Condition
0.1 second	0.1 second	Fiber out-of-frame or fiber loss of signal.
0.5 second	0.5 second	In frame, fiber channel down. The fiber channel communicating between the DS1 Converter and the other fiber endpoint (EI or SNI) is down.
1 second	1 second	In frame, control channel down. The control channel between the two DS1 Converters in the DS1 Converter complex is down.
2 seconds	0.2 second	No response from the server . The server is not acknowledging messages from the DS1 Converter or the communications link to the server is down.

1 of 2

Table 23: DS1 Converter yellow LED flashing states (continued)

LED on	LED off	Condition
solid on		DS1 Converter active. This is the normal state for an active DS1 Converter .
	solid off	DS1 Converter standby. This is the normal state for a standby DS1 Converter in critical reliability configurations (duplicated PNC).
2 of 2		

SPAN LEDs

The four SPAN LEDs indicate the status of the four T1/E1 facilities. A SPAN LED is in one of the following states:

- Solid on yellow: Facility is operational and alarm free.
- Blinking yellow for 2 seconds, off 0.1 seconds: Facility is operational and alarm free AND is carrying the control channel (facility A or B only).
- Solid on red: Facility is alarmed.
- Solid off: Facility is not administered or has been busied out.

Index

Numerical

110A-type terminal blocks (G650)	19
110P-type terminal blocks, frame-mounting	24
110-type hardware	17
110-type hardware, SCP-110 sneak current protection	54
110-type terminal blocks	19
110-type terminal blocks, wall-mounting	21
1110A2 apparatus mounting frame	24
1110C1 cable support	24
1145B power supply	109 , 110 , 114
1145B power supply, mounting	111
1146B power distribution unit	114 , 117
1146B power supply, mounting	111
1151B1 and 1151B2 power supply	132 , 133
1151B1 power supply	131
1151B2 power supply	131
1152A1 power distribution unit	119
connecting	120
connecting cables	121
258A adapter	43
26B1 selector console	87 , 88
2-wire and 4-wire endpoints, dual wiring	87
2-wire digital station wiring	75
302D attendant console	87
356A adapter	43
3-pair and 4-pair modularity	84
3-pair modularity	67
3-pair to 4-pair station circuits	44
3-pair trunks, cabling	38
451A extension adapter	42
4C3S-75 enhanced protector	94
4C3S-75 enhanced protector, installing	95
4-pair station circuits	44
808A emergency transfer panel	96 , 99
808A emergency transfer panel examples	97

A

adapter	
258A, 356A, BR2580A, ZD8AJ	43
451A extender	42
adjunct power	73
connecting	74
connection locations	85
administering patch cords and jumpers	62
alarms	147
connections	88
terminal alarm notification	148
wiring	75

analog line circuit protectors	93
analog station wiring	75
analog telephones	91
analog tie trunk wiring	76
announcements	
deleting	145
playback procedure	145
recording	145
testing	144
attendant console	86
cabling distances	86
installing	87
LEDs	147 , 148
maximum cabling distance	73
testing	143
auxiliary cabinet	
cabling to MDF	39
auxiliary connector outputs	81
auxiliary power	86
alarms	88
attendant console	86

B

back-up battery	115
battery	
back-up	114
mounting	115
BR2580A adapter	43

C

C360 converged stackable switches	128
C360 switch	
connecting	130
safety instructions	128
using the C360 switch	129
cabinet	
cable clamps	13
cabling to MDF	38
cable clamps	25
cable clamps, for cable slack manager	13
cable routing guidelines	36
cable routing, MDF	36
cable slack manager	13
cable slack manager, installing	25
cables	
25-pair I/O	13 , 25
attendant console cabling distances	86
installing	33

Index

installing between cabinet and MDF	38
outputs for control carrier	81
cables, installing between auxiliary cabinet and MDF .	39
cabling	
installing trunk cables	38
labels	33
provisioning plan	52
cabling layout	13
calling queue	107
carbon block protectors	
off-premises connections	93
checking	
circuit pack configuration	137
system status.	136
circuit packs	
configuration, testing	137
DS1 converter LEDs	148
duplication interface LEDs.	148
LEDs	147
C-LAN connection, testing	147
closets	
site locations	41
CO trunk wiring	75
collocated DS1 tie trunks, wiring	78
concentrator cables, connecting trunk pairs	65
connect	
1151B1 and 1151B2 power supply.	133
adjunct power	74
external alarm indicators	88
connecting	
1152A1 power distribution unit.	120
C360 switch	130
connecting control carrier outputs cable	65
connection diagrams, station cables.	44
console	
attendant, testing	143
selector, testing.	144
control carrier cable labels	64
control carrier outputs cable	65, 81
coupled bonding conductor wires, installing	58
critical reliability	
testing systems	141
cross-connect fields, MDF	16

D

data link protector, installing	95
DC power	58
DID trunk wiring	75
digital line circuit protectors.	94
digital tie trunk wiring.	77
direct department calling	
testing queue warning indicator	144
downloading this book and updates from the Web . .	10
DS1 converter	

circuit pack LEDs	148
DS1 tie trunks, wiring	78
dual wiring of 2-wire and 4-wire endpoints	87

E

emergency transfer panel, installing	99
emergency transfer telephones	104, 105
emergency transfer units	96
emergency transfer, testing	145
equipment room	
cable routing	36
cabling labels	33
station circuit distribution from	44
expanded power distribution unit	115
expansion interface circuit packs, testing.	139
expansion interface exchange, testing	141
expansion links, service state	136
external alarm indicators, connecting	88
external alarm wiring	75
external ringing	
installing	106
testing	144

F

floor plans	13
-----------------------	--------------------

G

G650 Media Gateway	
110A-type terminal blocks	19
cross connecting to MDF.	29

H

hardware	
MDF	17
hard-wire bridging	87

I

I/O cables	25
information outlets, wiring design	41
installing	
26B1 Selector Console	88
4C3S-75 enhanced protector.	95
808A emergency transfer panel	99
attendant console	87
cable slack manager.	25
cables	33
cables between auxiliary cabinet and MDF	39
cables between cabinet and MDF	38
coupled bonding conductor wires.	58

coupled bonding conductors	58
data link protector	95
external ringing	106
ITW Linx enhanced protector	95
MDF	19
MDFMain Distribution Frame. See MDF	
patch cords and jumpers	62
patch panels	29
sneak fuse panels	54, 57
telephone power supplies	
procedures	109
telephones used for emergency transfer	104, 105
trunk cables	38
integrated announcement	
testing	144
IP network connection, testing	147
ITW Linx enhanced protector	94
ITW Linx enhanced protector, installing	95

J

jumper wires, connecting trunk pairs	67
jumpers, installing and administering	62

L

labels	
equipment room cabling	33
MDF	20
labels, control carrier cable	64
lead designations	
port circuit packs and telephones	76, 83
LEDs	
alarms	147
attendant consoles	148
DS1 converter circuit packs	148
power distribution unit.	118
T1/E1 status	150
light emitting diodes. See LEDs.	
locating the MDF.	19

M

MDF	
cabling	33
cabling to auxiliary cabinet	39
cabling to cabinet	38
connections	17
cross connecting media gateway	29
cross-connect fields.	16
emergency transfer connections	99
emergency transfer unit	96
hardware	17
installation	17

labels	20
location	19
off-premises connections	90, 91
media gateway	
cross connecting to MDF.	29
media gateway installation	
coupled bonding conductors	58
modularity	
3-pair and 4-pair.	84
mounting terminal blocks	21, 24
music-on-hold, testing	145

N

night ringing, testing	144
----------------------------------	---------------------

O

off premise protection	54
off-premises	
connections	91
digital line circuit protectors	94
protection	93, 94
station wiring	90
stations	91
out-of-building connections	91
out-of-building stations	91
outputs cable for control carrier	81

P

patch cords, installing and administering	62
patch panels	
installing	29
pin designations	
port circuit packs and telephones	76, 83
playback announcement, testing.	145
Port Assignment Record form	62
port circuit pack pin designations	76, 83
port network	
expansion interface exchange, testing	141
TDM bus, testing	140
power distribution unit.	118
power supplies for telephones	
1151B1 -48V	131
1151B2 -48V	131
installing and wiring	109
testing	116
primary protectors	
off-premises	
connections	93
off-premises connections	94
provisioning plan	52

Index

Q

queue warning indicator	107
testing	144

R

recorded announcement, testing	145
ringing, testing	144
routing cables to MDF	36

S

safety instructions	
1145B power supply	110
1151B1 and 1151B2 power supply	132
selector console	88
selector console, testing	144
service states, checking	136
site locations, adapters	41
sneak current	
fuse panels	54
fuses	54
sneak current protection	54
sneak current protection, installing	57
sneak current protectors	
off-premises connections	93 , 94
sneak fuse panels	13 , 54
sneak fuse panels, installing	57
sneak fuse, connector pinout	54
space requirements	
110-type hardware	13
cable slack manager	13
sneak fuse panels	13
SPAN LEDs	150
station cables	
sizing	13
wiring design	41
station circuit distribution	44
system status, checking	136

T

T1 CSU, and DS1 tie trunk	78
T1/E1 status LEDs	150
TDM bus	
service state	136
testing	140
telephone calls	
making test calls	143
telephone installation examples	97
telephone pin designations	76 , 83
telephones	
connecting	73

emergency transfer	104 , 105
terminal alarm notification	
alarms	148
terminal blocks	
frame-mounting	24
wall-mounting	21
terminals, connecting	44
terminating trunk transmission test types	146
terminating trunk transmission testing	146
test types, terminating trunk transmission	146
testing	
1145B2 power supply	116
complete configuration	135
emergency transfer	145
expansion interface circuit packs	139
expansion interface exchange	141
external ringing	144
integrated announcements	144
IP network connection	147
music on hold	145
night ringing	144
playback announcement	145
queue warning indicator	144
selector console	144
TDM bus	140
terminating trunk transmission	146
TN2312AP/BP	138
tie trunk	
analog wiring	76
digital wiring	77
TN2312AP/BP	
testing	138
TN799DP C-LAN circuit pack	147
tone clocks	
service state	136
trunk cables, installing	38
trunk pairs	
connecting with concentrator cables	65
connecting with jumper wires	67

U

uniform call distribution	
testing queue warning indicator	144
using this documentation	9

V

voice terminals, exposed environments	94
---	--------------------

W

wall-mounting plates	114
wiring	

1146B power distribution unit	117
2-wire digital station	75
alarm	75
analog station	75
analog tie trunk	76
battery	115
CO trunk	75
DID trunk	75
digital tie trunk	77
DS1 tie trunks	78
off-premises stations	90
procedures	69
telephone connection	73
wiring telephone power supplies procedures	109

Z

ZD8AJ adapter	43
-------------------------	--------------------

